

OSWEGO SPEEDWAY



2012-2013 OFFICIAL RULE BOOK

www.oswegospeedway.com

2012-2013 OFFICIAL RULE BOOK

TABLE OF CONTENTS

CHAPTER ONE- All Divisions	
Rule Book Overview	2-4
CHAPTER TWO - All Divisions	
Qualifying Procedures.....	5-6
CHAPTER THREE - All Divisions	
Handicapping Procedures.....	7-8
CHAPTER FOUR - All Divisions	
Racing & Scoring Procedures.....	9-14
CHAPTER FIVE - All Divisions	
Flagging Rules.....	15
CHAPTER SIX - 2012-13 Supermodified Car Specifications	
Chassis & Components	16-19
Engine & Gear Specifications	19-20
Tire & Wheel Specifications	20-21
Body Design and Dimensions.....	21-26
Brakes.....	26
Fuel Bladders and Fuels.....	26
General Supermodified Components.....	27
Roll Cage Specifications.....	28-29
CHAPTER SEVEN - 2012-13 SBS Car Specifications	
Engine Specifications.....	30-32
Chassis/Suspension/Components.....	32-38
Roll Cage & Cockpit Specifications.....	38-39
Fuel & Fuel Tanks	40
Tire & Gear Specifications	40
Car Dimensions & Body Design.....	41-44
CHAPTER EIGHT - All Divisions	
Cockpit, Driver & Pit Safety.....	45-48
CHAPTER NINE- All Divisions	
Protest & Violations of Car Specifications.....	49
Post-Race Inspection.....	50
CHAPTER TEN - All Divisions	
Push Vehicles	51
CHAPTER ELEVEN - All Divisions	
Speedway Policy Regarding Use or Possession of Illegal Drugs Or Substances	52-53
CHAPTER TWELVE - All Divisions	
Track Championship Point System.....	54
Car Numbers.....	55

CHAPTER ONE

RULE BOOK OVERVIEW- All Divisions

1. The rules, specifications and procedures set forth herein are designed to provide for the orderly conduct of racing events and to establish minimum acceptable requirements.
2. The interpretation and enforcement of the rules, as published herein, shall be determined by the Chief Tech Inspector, and reviewed, if required, by the Oswego Speedway Competition Committee. Their decisions shall be final in all respects.
3. **The Competition Committee consists of the following members:**
 - John Torrese, Owner**
 - Eric Torrese, Owner**
 - Chuck Handley, Race Director**
4. When a competitor is “subject to one or more penalties at the discretion of the Competition Committee” one or more of the following penalties could be invoked:
 - (a) Monetary Fine, b) Race Disqualification, c) Lap Penalty, d) Finishing Position Penalty, e) Handicapping Penalty, f) Suspension from Competition for a Definite or Indefinite Time, g) Loss of Championship Points
5. In the event a car is disqualified from the feature race, the driver of the car shall receive a handicap penalty of a feature win and no feature points. The car’s owner shall be awarded last place prize money.
6. If the Competition Committee invokes a monetary fine and/or championship point’s penalty in lieu of disqualification, the rest of the field shall NOT be moved up in the finishing order. The proceeds from the monetary fine shall be allocated to the appropriate point fund. The decision of the Competition Committee to fine and/or invoke a points penalty in lieu of disqualification and the amount of fine and/or points penalty are not subject to protest. However, the alleged rules violation which resulted in the fine and/or points penalty is subject to protest, unless otherwise specified.
7. By filling out and signing the accompanying “Official Registration Form” the participant agrees to become familiar with and abide by these rules, specifications and procedures as set forth in this Rule Book and prescribed subsequently by Oswego Speedway, its affiliates, officers or designated representatives.
8. No express or implied warranty of safety shall result from publication of or compliance with these rules, specifications and procedures and/or subsequent modifications. They are intended only as a guide for the conduct of the sport and are in no way a guarantee against injury or death to participants, crew members, spectators, track officials or others.

9. All specifications and regulations contained herein are subject to deletions, additions, and/or modifications by directives contained in subsequent technical bulletins, official entry forms, official programs and publications issued by **Circle T Amusements (hereinafter referred to as Oswego Speedway) or by verbal directive of track management without prior notification.**
10. All Oswego Speedway measuring and weighing devices shall be the official devices. Track scales are the official scales at every race meet. Engine spec. measurements using track P&G and/or Whistler shall be official measurements. Tech inspectors' findings with respect to weights and measurements using track equipment shall not be subject to protest.
11. The Competition Committee reserves the right to reject any car or driver entry on the basis of noncompliance with this Rule Book.
12. Race officials reserve the right to change the number of cars entered in any race, the number of races in any race meet and the number of laps in any race, at any time.
13. The use of equipment not available to all participants in the market place in adequate supply shall be subject to approval by the Competition Committee. Products need not be for sale on speedway grounds, unless the Competition Committee specifies otherwise.
14. The chief tech inspector reserves the right to check any car at any time for compliance with this Rule Book without prior notice given.
15. Any new components and/or equipment available in the market place, but not necessarily covered in this Rule Book, shall be brought to the attention of the chief tech inspector before being allowed to be used. The car owner and/or driver is subject to one or more penalties at the discretion of the Competition Committee for non-approval of the new components and/or equipment.
16. Track management or the Competition Committee reserve the right to change or modified any rules as they see fit, under whatever conditions that may dictate change.
17. Track management reserves the right to impound a car involved in any personal injury accident for up to 72 hours from the time of the accident.
18. All drivers, car owners and crew members shall release and relinquish to Oswego Speedway, any and all rights to publish, produce, copyright, duplicate or reproduce in programs, newspapers, periodicals, or upon hats, jackets, patches, decals, T-shirts, sweatshirts and any other novelty items, photos and drawings of their likeness or their race cars, written articles about them or by them and any other such item of every name and nature which may have originated from or be related to the events at Oswego Speedway. Further, if any event to which this Rule Book applies, is filmed, televised, videotaped or publicized, all drivers and car owners understand that such telecasting, filming, videotaping or publicizing may be done in such a manner as track management may see fit, and track management shall have the right to use the names of the drivers and car owners in connection therewith and such telecast, film, video or publicity or any future use thereof, shall in no way be construed as a violation of the drivers' or car owners' privacy and no compensation therefore shall be due or payable to the drivers and car owners from Oswego Speedway.

19. IN CONSIDERATION of the acceptance by Circle T. Amusements (Oswego Speedway) of my 2012-13 Official Registration Form, my being permitted on the Oswego Speedway premises for any event, or any of the foregoing, I for myself, my heirs, next of kin, personal representatives and assigns, FOREVER RELEASE, REMISE and FOREVER DISCHARGE and AGREE TO HOLD HARMLESS and INDEMNIFY OSWEGO SPEEDWAY the promoters presenting races or other events, the owners (lessors) of the premises on which Oswego Speedway events are presented, the participants thereon, and the owners, sponsors and manufacturers of all racing equipment used in Oswego Speedway events, the officers, directors, agents, employees and servants of all of them, including Oswego Speedway officials and Oswego Speedway license members, of and from all liability, claims, action and of possible causes of action whatsoever, including negligence of the foregoing, that may accrue to me, my heirs, next of kin and personal representatives from every and any loss, damage and injury, including death, that may be sustained by my person and property while in, about and enroute into and out of Oswego Speedway premises.

IMPORTANT!!! - The 2012-13 Oswego Speedway Official Registration and Medical Forms which accompanies this Rule Book shall be filled out COMPLETELY, signed and returned to Oswego Speedway before a driver and/ or car owner shall be eligible to participate in 2012-13.

Please mail to:
Oswego Speedway
300 E. Albany St. - P.O. Box 3043
Oswego, NY 13126

CHAPTER TWO

QUALIFYING PROCEDURES - All Divisions

1. Everyone entering the pit area shall purchase and wear a pit wrist band. A driver under the age of 18 must sign and must have his parents sign a Minor Release Form to be eligible to compete. The driver must also produce a copy of his birth certificate. No one under the age of 16 can compete in any division.
2. Each pit entrant must sign a liability waiver and release form at each race meet or warm-up session. By signing the release form, you or your heirs cannot sue the track for relief if you are injured or killed; the insurance benefit plan arranged for you is your relief.
3. Anyone injured in the pit area shall report his or her injury to one of the track medical personnel before leaving the premises. Failure to report an injury to the medical staff shall forfeit any medical claims.
4. The maximum height of a car hauler and tow rig allowed into the pit area shall be 10-1/2 ft. measured from the ground to the highest part, including air conditioners, tire racks, spectator rails, etc.
5. All cars shall pass a pre-race technical and safety inspection at each race meet before they are allowed to run.
6. Each car and driver combination shall be registered with the chief pit steward before entering into competition at each race meet. At registration for each race meet, the driver shall inform the chief pit steward which class (supers, SBS or etc.) he wishes to compete in. Any change in registration of car and driver combinations at a race meet shall be made to the chief pit steward and shall be governed by all rules of handicapping and qualifying procedures.
7. Any car which has been judged to be mechanically fit, appears from the pre-race technical inspection to meet all car specifications, is registered for the current race meet and has a registered driver is eligible to be placed into competition.
8. Only registered drivers scheduled to drive in competition at each race meet shall be allowed on the track at any time unless given special permission by the chief pit steward. Anyone starting a car in the infield shall be buckled in and have all safety equipment on, including helmet, firesuit and gloves.
9. All new drivers competing at Oswego Speedway for the first time shall report to the chief pit steward to be briefed on general rules of conduct. The new driver shall then report to the track manager, who shall brief him or her on general driving procedures and arrange to have one of the veteran supermodified drivers take him out onto the speedway in the pace car for further instruction. The Race Director shall then give consent to the chief pit steward to allow the new competitor onto the racing surface. Failure to abide by this procedure or failure by a new driver to obey the rules set down by the chief pit steward and Race Director shall result in all driving privileges being taken away.
10. All new supermodified drivers at Oswego Speedway shall relinquish the regular warm-up periods in lieu of special warm-up sessions called "Rookie Warm-ups", at the discretion of track officials.

11. Each registered car and driver is limited to one qualifying heat race appearance. Any car may qualify for the feature race by competing in a heat or a consolation race.
12. A driver shall qualify the car he drives in the feature:
 - a) When a qualified car becomes mechanically unfit to race and is called "out for the night" the driver may qualify another car in the consolation race.
 - b) When a driver of a qualified car becomes physically incapable of driving, the car he qualified may be re-qualified in the consi for the feature race by another driver.
 - c) If a driver wants to qualify another car in the consi even though his car is already qualified through the heats and able to run, he shall relinquish the position of the car already qualified to be eligible to qualify the other car. In all cases, the driver shall receive championship points for the heat in which he participated and an additional qualifying spot shall be taken from the consi.
 - d) Failure to report any driver changes to the chief pit steward shall result in a scratch position start or possible finishing position penalty.
13. There shall be no substitution of feature cars. Any qualified cars unable to compete shall be replaced by consi cars. If a full starting field is not set after the consi is run, however, the field shall be completed by the highest point driver not already qualified using any car available in the pit area, provided that the car chosen was on the track at least once during the race meet. If all point drivers are qualified, a driver who is registered for the current racing season and was on the track at least once during the race meet shall qualify.
14. Relief driving shall be allowed only after the feature event has been started. No relief driving during the preliminary events. If there is a driver change during a red flag situation the car shall be brought to the pits and start at the rear of the field upon returning to the track. Relief driver shall be a currently registered driver. The driver that starts the feature shall be awarded the championship points.
15. All cars shall start in their assigned position unless prior notice has been given to the chief pit steward. If starting position changes are made prior to the event, a new lineup of all cars shall be made before racing is started. Failure to report any changes shall result in a scratch position start or possible disqualification.
16. A "rookie" shall be defined as a driver who has QUALIFIED for a feature at 3 race meets or less in any previous year and more than 3 race meets in the current year or who has received show-up points at 6 race meets or less in any previous year and more than 6 race meets in the current year. Non- points events , in any division, are not considered when determining rookie status. The "Rookie of the Year" shall be determined by the rookie driver who finishes highest in the Championship point standings at the end of the year. A driver who has raced in a previous year, but is eligible to run for "Rookie of the Year" must start behind all handicapped cars in the heats for three race meets regardless of points earned.

CHAPTER THREE

HANDICAPPING PROCEDURES - All Divisions

1. Cars shall be numbered using a maximum of two digits. No letters or symbols shall be allowed. Backup cars entered into competition shall have a different two digit number from the main car.
2. Changing numbers on any car shall require re-registration of that car.
3. In order to maintain a car number for the upcoming season, the car shall have competed in at least 6 race meets during the past season and the car owner shall request the number, in writing, before March 1st of the upcoming season. If a car has not competed in 6 race meets during the previous season, the car owner shall submit, in writing, the number he wishes to run plus two alternate numbers. A car number shall be issued by the chief handicapper on a first come-first served basis. The car owner shall be contacted either by phone or by mail regarding his number for the upcoming racing season.
4. **New owners of previously registered cars shall report the transfer to the chief pit steward and furnish him all pertinent information.**
5. If a driver is deemed to be lacking experience in race competition, driving in an erratic manner, unable to maintain a consistently fast speed or unable to maintain a consistent groove, race officials may start his car behind all other regular handicapped cars in any event.
6. Any driver and/or car that does not warm-up shall start scratch in his heat.
7. A driver shall not be able to run more than one qualifying heat per race meet.
8. At the conclusion of warm-ups race officials shall determine and announce the following:
 - a) the number of heat races and consolation races in each division,
 - b) the number of cars qualifying from each preliminary,
 - c) the number of cars that shall start each feature, and
 - d) the number of qualified cars from each heat that shall start the features in their handicapped positions.

9. POINTS EARNED HANDICAPPING SYSTEM—

A driver's starting position, unless otherwise specified below, shall be determined by the number of championship points earned, or money won, over the past 3 race meets. The driver with the least number of points earned shall start on the pole; the driver with the second lowest number of points earned shall start outside pole, etc. If a driver is not in attendance for a race meet he shall be credited with heat and feature win points for handicapping purposes. Drivers who have never started a feature race and all drivers eligible for "Rookie of the Year" in any division shall start behind all other cars for three race meets, regardless of points earned.

10. HANDICAPPING

- a) Heats - Lineup for heat races shall be selected randomly from all drivers in attendance using the points earned handicapping system. A driver who wishes to run a late heat (or early heat) shall report this to the chief pit steward within 5 minutes after the completion of warm-ups. Once the heat

lineups have been given to the chief pit steward, **the driver shall either start in his assigned position or swap heats with someone in the same position.**

- b) Consis - Lineup for the consis shall be straight up from the heat race results. The first non-qualifier from the heats shall start on the pole; second non-qualifier shall start outside pole and so forth. These drivers shall be followed by drivers who did not compete in the heats and new or inexperienced drivers. The balance of the feature starting field shall come from this event.
 - c) Features - Lineups for all supermodified and SBS features shall be determined by using the points earned handicapping system for drivers qualifying in handicapping positions in the heats, except as specified below. The balance of the field shall start straight up from the non-handicapping positions in the heats, followed by the consi qualifiers and the provisional starting spot.
 - d) **The Mr. Supermodified and Mr. Small Block Feature line-ups shall be determined by using year-long handicapping based on points for the entire season and THROWING OUT THE THREE (3) WORST FINISHES. Missing any weeks will result in being credited with a Heat and Feature win.**
 - e) **On Opening Day for both SBS and Supermodifieds we will use transponder times to line-up Heats and Features. The top 12 fastest times will be inverted in the Heats. The top 12 out of the Heats will redraw 1-6 and 7-12 for the Feature line-up. The week #2 event will be based on week #1 results. No handicapping from the previous year will be used.**
11. **A provisional starting spot may be added from Commitment and Non-Commitment Owners. No more than two (2) spots can be added to any feature. Commitment Owners will be able to use their provisional two (2) times during the regular season. Only one (1) Commitment Owner per Feature can be used and will be determined by highest owner in points. Non-Commitment Owners will be able to use their provisional once during the regular season. We will only use one (1) Non-Commitment Owner per Feature. Classic Weekend both SBS and Supermodified provisionals will be the highest Commitment Owner in points that has fulfilled their Commitment Agreement. They will start last in the field and must attempt to qualify in all qualifying races. To use any provisional spot you must have attempted to qualify in warm-ups, Heats or Consi.**
12. a). **Pit stalls from the previous year will be held until January 1st. After that all pit stalls shall be released. You do not have to purchase a pit stall but will have to park where the Chief Pit Steward instructs you to.**
- b). **All Commitment Agreements, Registrations and Pit Stall Reservations must be handed in to the Speedway Office by January 1st.**

CHAPTER FOUR

RACING & SCORING PROCEDURES - All Divisions

1. At the advertised starting time, competitors in the first heat shall grid their cars in the pit area. Pit steward shall direct the field onto the track and they shall line up single file behind pace car. Scuffing of tires shall be allowed at that time. The race director shall instruct the field into rows of two. At that time tire scuffing shall stop and the white flag shall be shown on the next lap. This procedure shall be repeated for all subsequent heat races. Supermodifieds shall enter the track under power. Consolation races shall be conducted in the same manner. For the features, limited supermodifieds shall enter the track under power. Supermodifieds shall be pushed onto the track out of gear and stop in the first turn behind the pace car. During all races, any car entering the track after cars have been instructed to assume their starting positions (rows of two) shall relinquish its starting position and start at the rear of the field, provided the car enters onto the track before the white flag has been displayed. In the event of a shortage of push vehicles, supermodifieds shall line up at the first turn pit push off stripe, away from all crew members.
 - a) Radios must be on and properly working at all times while on the track, warm-ups, heats, consis, and features. No cars will be allowed on the track without a working radio. During a heat, consi, or feature, if your radio does not work or your seat belts come unhooked, you may stop at the start/finish line for assistance by track personnel. You may return to your track position without penalty. This safety related stop will be allowed **ONLY ONCE PER SEASON**. If it happens a second time during a season, you must go to the pits, fix the problem, and restart at the end of the field. If during a race the race director determines your radio is not working, you **WILL BE BLACK FLAGGED TO THE PITS**, to repair your radio, if you have already used your one safety related stop.
 - b) Supermodifieds cannot be push started during **ANY OTHER** feature events. You may fire in between or during Victory Lane ceremonies.
2. Cars being pushed for starting shall stay to the inside of the racing surface. Cars being forced to pit during pace laps prior to the start of a race shall be allowed to return at the end of the field provided the white flag has not been displayed. If these cars are unable to return the bubble cars shall be called as replacements. A minimum fine of \$25.00 shall be levied against a car for excessive speed in the pits. A \$100.00 fine shall be levied for each successive infraction during the same season.
3. Any car passing the pace car once the field is pushed off for the purpose of gaining a warm-up lap shall forfeit its assigned starting position.
4. All repairs shall be done in the pit or infield area. No repairs shall be made while on the racing surface, pit entrance or exits. Offenders shall be black flagged to the pits and may not be allowed to return, at the discretion of race officials.
5. All races shall get the initial green flag when the two front row cars reach the 4th turn starting line. No passing or moving out of line until the green flag is waved. Penalty for either shall be as specified in paragraph 11 below.
6. If the front row is uneven at the start of the race, the race shall be yellow

flagged and both front row cars shall receive a warning from the starter. If there is another "ragged" start, one or both front row cars shall be placed to the rear of all other cars and the second row shall then become the front row.

7. On the initial starts, any driver who creates a dangerous situation by making a "low move" down the front or back straightaway, shall be subject to one or more penalties at the discretion of the Race Director.
8. On a false start, the green flag shall be given followed by a caution flag on the backstretch in order to avoid a first turn mishap.
9. If a yellow flag occurs on the first lap, it shall be deemed a complete double file restart, provided caution laps don't count. In longer races, when caution laps count, once the green flag is given the race has officially started and all laps count even if a yellow occurs on the first lap. If a car "jumps" the start of a cautions count feature, the car shall be penalized as specified in paragraph 11 below.
10. All restarts after one completed lap shall be single file. All restarts that occur within the last ten laps of a feature race shall be lined up as follows: all cars on the lead lap running in the track position scored on the last completed lap prior to the yellow, followed by cars down one lap or more running in the track position scored on the last completed lap prior to the yellow flag. **FOR ANY CAUTIONS COUNT RACES THE LAP CARS WILL NOT BE PUT TO THE REAR.** Once the white flag has been given on these restarts, cars shall remain in single file and one behind the other until the leader reaches the restart stripe in turn 3 and the green is displayed. Once the leader reaches striped yellow line on the backstretch, he shall begin a gradual acceleration, reaching race speed at the restart stripe in turn 3. Should the restart be considered unfair or unsmooth the leader shall receive a warning from the competition director. If there is another "ragged" restart, the leader shall be placed at the rear of the pack, on the lead lap. The penalty for lining up offset or passing under caution on a restart shall be as specified in paragraph 11 below.
11. The penalty for violation of the start or restart procedures, as specified in the above paragraphs, shall be the loss of position on the lap the penalized car is running. **When the false start or restart penalty has been imposed, the tower will inform the Chief Pit Steward who will inform the crew chief of the penalized team. On the next restart, the penalized car shall be sent to the rear of the pack, but will not lose a lap. If there is no subsequent restart after the penalty has been imposed, the penalized car shall be scored to the back of all other cars on the same lap it was running at the end of the race.**
12. Any car which delays the start of a race during the pace laps by slowing or stopping on the track shall be motioned into the pits and be replaced by the bubble car, but shall be allowed to return at the rear provided the white flag has not been displayed.
13. At the start of any race when the cars are double file, there shall be no swerving of cars to scuff tires. Competitors caught in the act shall lose their starting position and start scratch.
14. Any car which dumps liquid (oil, rear end grease, fuel, water) onto the racing surface shall be brought off the track immediately and may not be allowed to return, at the discretion of race officials.

15. Any car that deliberately stops on the racing surface or intentionally spins to cause a yellow flag and then attempts to rejoin the race shall be black flagged to the pits and may not be allowed to return, at the discretion of race officials.
16. All supers leaving the racing surface during practice shall use the 3rd or 4th turn pit entrance. All small blocks and other divisions entering the pits from the track shall use the 3rd turn pit entrance. All supers exiting the track during a race under green flag conditions should use the 3rd turn pit entrance. However, in an emergency either the front, 3rd turn or 4th turn entrance may be used.
17. Any car which receives the white flag in any race is considered to have started the race and shall be paid and scored accordingly. During feature races when we have a good lineup and start warm-up laps, all cars on the track will be considered as having started the feature. You do not have to take the white flag. In heats and consolation events a car must take the white flag.
18. For the feature race, consolation or bubble cars shall fill out the field in the scratch positions if the field is not complete, provided they are ready to be pushed off onto the track, prior to the white flag. In the event a car pulls off on any of the pace laps, prior to the white flag, the race shall be relined.
19. When a race is slowed or halted all cars which necessitated the race to be slowed or halted shall be placed to the rear of the field in the order which they finished the last completed lap, if they are able to restart. Cars causing a yellow flag shall be placed to the rear of the field in the order in which they were originally scheduled to start the race if the accident occurs on the first lap.
20. If a car causes contact, and a yellow flag is displayed for that contact, but continues through the accident scene, that car could be deemed as causing the yellow and will be penalized to the rear of the field. All other cars involved could also be sent to the rear. Any car that spins or stops to avoid the initial contact, that caused the yellow, will be returned to their position on the track. All decisions will be made by the race director after conferring with the flagman and corner men. All decisions are not protest able.
 - a). If there is a restart and then another yellow with no more laps complete, any car restarted will be scored ahead of any car that did not restart from the first caution.
21. All cars not able to resume racing after a race is slowed or halted shall be scored by the number of laps completed. Cars with the same number of laps completed shall be scored as to how they were running in relation to each other on the last completed lap before the race was slowed or halted, except that those cars causing the yellow or red flag shall be scored at the rear of all cars completing the same number of laps.
22. A precautionary or "courtesy" yellow flag may be waved by a flagman for an impending crash, a car "out of shape" or other potential safety hazard. In this particular situation, the car or cars in question may not be penalized, at the discretion of race officials.
23. Scuffing of tires shall be allowed during caution periods when there is a single file restart, away from the accident scene. Any drivers scuffing tires or running double file through an accident scene shall be sent to the back of the pack on the restart.

24. If the same car causes multiple caution periods during a racing event, that car shall be subject to disqualification and removal from the racing surface, at the discretion of race officials.
25. If a race is slowed or halted because of adverse track conditions, no cars shall be penalized.
26. In the event of a red flag situation, all cars shall STOP as quickly and safely as possible at any point on the race track and away from the accident scene, leaving the very inside lane open for emergency vehicles. During a red flag, all vehicle movement in the pit area shall also cease. Once the emergency situation has been brought under control and the red lights are turned back to yellow, cars may then be taken to the pit area by push trucks, but cannot fire up on the track. No work shall be done on the car while stopped on the track. No refueling of cars while stopped on the track unless specified by race officials. Cars shall restart in the order of the last completed lap for cars remaining on the track followed by cars in the order in which they return to the track from the pit area.
27. Any car which pits during green flag racing may re-enter the race under its own power at any time. The car shall be charged with all laps lost while it is out of competition. The lap in which the car returns to competition under the green shall not be scored.
28. **Cars that are slow, erratic or unable to maintain a consistent groove**, shall be black flagged off the race track and may not be allowed to return, at the discretion of race officials.
29. All supers leaving the pit area during competition shall do so under their own power. Supers are to be pushed, out of gear, to the first turn starting stripe, come to a complete stop, engage drive line and be pushed off. Supers that do not fire up by the second turn exit shall stay in the infield and attempt to refire using the aforementioned procedure. No push trucks shall be allowed on the racing surface during the race. Small Block and other divisions shall stop at the second turn starting stripe and be motioned by the pit steward to leave the pit area and return to the speedway.
30. Any car may be taken to the pit area during a yellow flag situation (or in a red flag situation AFTER they have stopped completely and the emergency situation has been brought under control) and may re-enter the race at any time. If the car re-enters on a yellow flag situation, it shall be placed at the rear of the pack on the lap it was running when it entered the pits. If the car enters in the middle of the pack on the green flag lap, it shall be scored as “down one lap.”
31. When the white flag is displayed for all starts and restarts, all corner lights shall be turned out. If the caution lights come on and the corner men show the caution flag during the “white flag lap” it means that you shall NOT receive the green on the next time by the starter. You shall slow down, stay in line and receive further instructions from the starter.
32. If a car has been in an accident and the damage is extensive enough to prevent it from continuing in that race, the car shall be reinspected by a tech inspector before being scheduled in another race. Any car that has been in an accident may or may not be allowed to start in its earned handicap position in the next race after the crash, at the discretion of race officials.

33. Any driver deemed to be rough riding, driving in an erratic manner, displaying unsportsmanlike conduct or disobeying race procedures, qualifying procedures or flagging rules shall be subject to one or more penalties at the discretion of the Competition Committee.
34. Once the starting lineup is set for the super and small block feature, the pace car shall be brought into the pit area and the cars shall be given several hot laps to bring tires and engines up to racing temperatures. The bubble car shall not be allowed to participate in this hot lap session at the rear of the field. For the supers, all caution laps from the initial push off shall be counted towards a fuel stop. All cars shall be stopped for refueling after 60 caution laps have been run. The number of caution laps run shall be counted by race officials and is not subject to protest. Only 2 crew members per car shall be allowed on the racing surface to refuel. No repairs shall be allowed on a car without returning it to the pits. There shall be no refueling provisions for preliminary events, unless deemed necessary by race officials.
35. All races shall be run until the leader of the race receives the checkered flag. In the event of a yellow flag after the checkered flag, the cars which did not complete the race under the checkered flag shall be scored in the order in which they finished the last completed lap. Cars which caused the yellow shall be placed to the rear of the order. If a restart is delayed by rain and subsequently checkered, cars shall be paid in the order in which they would have restarted the race.
36. If a driver fails to present himself in Victory Lane after winning any race to accept a sponsorship presentation, he is subject to one or more penalties at the discretion of the Competition Committee.
37. The official order of finish shall be determined by the total number of laps completed. When two or more cars finish with the same number of laps completed, the higher finishing position shall be given to the car that finished the same number of laps first. **Unless, there are multiple cautions for the same lap. Then cars in the last caution will be scored ahead of cars in the previous cautions.**
38. **Videotape that is produced during any given race meet may be used by race officials to help make race decisions, but the final decision shall be made by race officials without regard to the videotape if it is deemed to be inconclusive.**
 - a) **Official finishes at the line will be determined by scoring on the transponder system. Placement of transponders must be at the exact location according to the rulebook. Any transponder blatantly placed forward of this location will cause the car to be disqualified. Checking of transponder location will be done randomly at all tech inspections.**
39. Following the completion of scoring after each feature race, the official order of finish shall be announced and/or posted at the base of the judge's stand. All protests shall be made within 5 minutes and shall be in writing on the Official Protest Form available at the base of the judge's stand. Only one member from the crew filing the protest shall enter the judge's stand to question the results.
40. During the race meet, including the protest period, any driver, owner or crewman under the influence of intoxicating beverages or drugs of any kind, shall be removed from the speedway grounds and shall be subject to one or

more penalties at the discretion of the Competition Committee. In addition, their protest shall be immediately rejected.

41. The car owner is responsible for the conduct of his entire race team, including the driver. Professional conduct is expected from each race team while on the speedway premises. If an altercation occurs between a competitor (owner, driver or crew member) and a track official or between competitors on the speedway premises, which results in physical assault, the competitor(s) directly involved shall be subject to arrest and denied further entry to the speedway for a period of time, to be determined by the Competition Committee. In addition, the car owner(s) affiliated with the competitor(s) directly involved in the altercation shall be subject to one or more penalties, at the discretion of the Competition Committee. Penalty for first offense is appeal able, but penalty for second offense in the same race season is not subject to appeal. If any member of a race team involved in an accident or situation goes to the pit area of another team involved in the accident or situation or comes to that teams defense, with no invitation, immediate disqualification will occur. Disturbances, name calling, or fighting between competitors will not be tolerated.
42. When a race meet is halted because of weather conditions, all laps run shall be scored. In the event racing is unable to be continued the following schedule shall be used: If all heats have not been run, rain checks shall be honored for the rescheduled date of that particular race meet. Race officials reserve the right to keep or cancel the preliminary races run before the race meet was halted.
43. If a race meet is postponed after the heats and consi have been run, rain checks shall not be honored. All races remaining to complete the postponed race meet shall be rescheduled and run as the first part of a future race meet. All cars shall start the rescheduled race meet in the positions earned prior to the time the race meet was postponed.
44. If more than half of the feature race has been run and it is unable to be completed due to weather or track conditions the race shall be considered complete, all positions shall be paid according to the order of the last completed lap and championship points shall be awarded to the drivers.
45. If less than half of the feature race has been run and has to be postponed to a later date, all cars that originally started in that particular feature race shall be allowed to restart. Cars that were already out of the race at the time of the postponement shall restart the race in the rear. Their restart positions shall be determined by the total number of laps completed.
46. Should a race meet be halted at a time when it could not be continued on a future date in the same season, any posted prize money shall be paid for all races completed and positions held by the cars at the time the race is halted. If less than half of the feature event has been run, no championship points shall be awarded.

CHAPTER FIVE

FLAGGING RULES - All Divisions

If a driver does not comply with the following flagging rules, he is subject to one or more penalties, at the discretion of the Competition Committee. Any decision with respect to flagging rules is not subject to protest.

WHITE FLAG: Cars shall receive the white flag one lap prior to the start and restarts of all races; and one lap prior to finish of all races.

GREEN FLAG: Shall be waved as the lead cars reach the 4th turn starting line for the start of all races. On restarts the green shall be given as the leader reaches the restart stripe in the 3rd turn.

RED FLAG: Shall be displayed in the event of a serious accident on the race track. All cars shall stop as quickly and safely as possible at any point on the race track and away from the accident scene. Leave the very inside lane open for emergency vehicles.

YELLOW FLAG: Shall be displayed in the event of a minor accident or spin. All cars shall proceed at a reduced speed in single file. The pace car shall pick up the leader. All yellow flag laps shall be counted for fuel consumption.

BLACK FLAG: Shall be displayed to bring a car into the pits from the race track for consultation. Car number shall be displayed on Black Flag Board over the score board in the first turn

PASSING FLAG: Shall be displayed as a warning to slower or lapped cars that they are being overtaken by the leaders of the race. Cars being lapped shall hold their line. **Cars that are being lapped and racing for position may continue to race but should be aware that the leaders are coming. Cars that are alone should leave the outside lane open.**

CHAPTER SIX

2012-13 SUPERMODIFIED CAR SPECIFICATIONS CHASSIS & COMPONENTS SUPERMODIFIED CHASSIS

1. The supermodified chassis (frame) must be made with SAE 4130 condition "N" seamless steel tubing. This includes the chassis, all cross members and diagonals. The bumpers and nerf bars can be made from mild steel. The main frame rails, including the roll cage, must be made with 1.5" O.D. and .095" wall thickness. The cross members in the cockpit area must also be made of 1.5" O.D. and .095" wall thickness. The chassis must have adequate diagonals which must be a minimum of 1" O.D. and .065" wall thickness or equivalent. The vertical diagonals in the cockpit area must be properly spaced to prevent a front bumper from contacting the driver in the case of a side impact.

The cockpit area of the chassis, including the roll cage, must be a minimum width of 17" and a maximum width of 24" measured inside the frame rails.

The roll cage must be of a height that the top of the drivers helmet, while strapped in race position, is completely below the underside of the roll cage. A four (4) inch distance between the drivers helmet and the bottom of the roll cage is recommended.

The roll cage shall be incorporated as part of the chassis construction and shall be attached to the frame in four (4) locations to the upper frame rails. However it is recommended the roll cage up rights connect to the lower frame rails. The roll cage uprights will have a corner gusset a minimum of 3" away from the joint, where the roll cage uprights attach to the upper frame rails, to prevent the separation of the roll cage from the frame. The gussets will be a minimum of 1"O.D. and .065 wall thickness. The roll cage must have an x brace or v brace to support the rear roll bar hoop. These braces must be made of a minimum of 1"O.D. and a minimum wall thickness of .065". The rear roll cage hoop must have additional braces (one on each side) that extend from the upper frame rails to at least half way up the height of the rear hoop. These braces should be at a 45 degree angle and be made of 1.5" O.D.*.065 wall thickness.

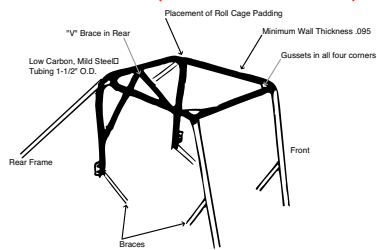

2. The wheel base (the distance from the center of the front axle to the center of the rear axle) can be not less than 90" or longer than 100".
3. The supermodified shall be rear wheel drive only. 4 wheel steering or rear wheel steering will not be allowed.
4. The 4 wheels shall be located in the standard position; left front, right front, right rear, and left rear.
5. The engine shall be mounted in the standard location; front of the engine facing forward and the rear of the engine facing rearward. The entire engine will be located in the front 2/3 of the wheel base ahead of the driver. No reverse rotation engines.

6. All components, including headers, engine, oil tank, and radiator may not extend beyond the outside edge of the tires.
7. There shall be a firewall between the engine and the driver. A steel or aluminum plate at least 1/16" thick shall be adequately fastened to the frame between the engine and the driver. This firewall must be sealed to prevent fluid or fire from coming in contact with the driver.
8. The drivers torso must be located behind the engine, to the right of the engine, and front of the rear axle.
9. No articulating chassis.
10. Streamline tubing is permitted, but can't be used for diagonals or cross members in the main structure (center section). Below is a chart that will help enable you to choose the correct streamline tube size. The wall thickness in this case is only an example, but the comparison would be the same if the wall thickness you choose is thicker.

Major Axis	Minor Axis	Wall	Equivalent		Wt./ Ft.
			Round Tubing Tension	Tubing Compr.	
1.012	.428	.035	3/4"	1/2"	.2687
1.180	.500	.035	7/8"	7/16"	.3140
1.349	.571	.049	1"	5/8"	.4977
1.685	.714	.049	1-1/4"	3/4"	.6285
2.023	.857	.049	1-1/2"	1"	.7593
2.360	1.000	.049	1-3/4"	1-1/8"	.8902
2.697	1.143	.049	2"	1-1/4"	1.021
3.372	1.429	.049	2-1/2"	1-1/2"	1.283

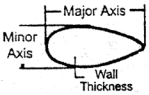

The diagram shows a cross-section of a streamline tube. The horizontal dimension is labeled 'Major Axis' and the vertical dimension is labeled 'Minor Axis'. The thickness of the tube wall is labeled 'Wall Thickness'.

FRONT and REAR SUSPENSION

1. The maximum width of the front end and rear end shall be 85". This is measured from the outside of the bead area of the wheels.
2. Independent front or rear suspensions are not permitted.
3. The front axle must be made of steel and go directly from the right side spindle to the left side spindle with no interruptions. Any type axle construction may be used. The axle may be 2 piece to prevent binding, but can't allow the front wheels to work independently of each other vertically. Any spindle may be used.
4. The rear end can be a quick change or non quick change. Front load quick changes are not permitted.
5. The lowest gear ratio allowed is 4.12
6. The rear axle can be steel or aluminum only and must be a 3" open tube design. No homemade rear axles allowed. The rear end assembly must be of standard design (i.e. Winters 637S, Halibrand, DMI etc). with rear end gears facing toward the rear of the car. Any other designs must be approved by Oswego Speedway tech. **Titanium is not permitted.**
7. The supermodified shall have 4 wheels with 2 rear wheel drive and front wheel steering. No four wheel drive, front wheel drive, four wheel steering or rear wheel steering shall be allowed. The 4 wheels shall be located in the standard positions: left front, right front, left rear, and right rear.
8. The driveline shall run directly from the engine to the rear end. No transfer case assemblies, clutches, transmissions or hydraulic couplings of any kind shall be allowed. In-out boxes are allowed.

9. The cockpit shall be located within the wheel base.
10. The driveshaft shall be steel or titanium and should be painted white for visibility. The driveshaft shall be located outside the main frame rails, and must run directly from the crankshaft flange to the rear end flange. The driveshaft must have 2 driveshaft guards located 3" to 5" away from the joints. They shall be constructed of "x 2" steel and properly fastened to the chassis or nerf bar.
11. No transmissions allowed.
12. A safety chain or cable shall be fastened from the torque arm to the chassis.
13. Supermodifieds must have 4 shock absorbers, one(1) on each wheel. Shock absorbers can have no more than 2 adjusters. Any shock absorber manufacturer is permitted. Any shock canister is permitted. No knee action or rotary shocks are allowed.
- 14 Springs must be steel magnetic.
15. Any type suspension can be used providing it meets the previously mentioned rules.
16. All cars shall have an engine belly pan located under the engine. The belly pan shall be flat on the bottom, have NO Aerodynamic properties and be of size, shape, and material capable of holding entire liquid contents of car's engine. The belly pan shall be fastened directly to the bottom of the frame of the car. The use of a fireproof absorbent pad in the belly pan is highly recommended.
17. All cars shall run a fully functional Schoenfeld 103535K - 10" or 112535 - 11" muffler that is unaltered. No homemade mufflers or baffle systems allowed. Mufflers shall be connected on the end of the header pipes and the kick out should be positioned at a 45 degree angle to the ground.
18. All supermodifieds shall be equipped with a hook or loop mounted as near as possible to the center of gravity of the car, capable of supporting the entire weight of the car. This device/location shall be brightly colored and bolted or welded to the frame or roll cage and be of appropriate size and shape so the vehicle can be lifted into the air, in a level position, by a tow truck. The roll cage, if it provides the best balance point, may be marked and utilized for the lift point. No muffler clamp-like devices allowed.
19. No modifieds, small block supers, sprinters or cars identified as such shall be allowed to compete with the supermodified division.
20. No fan cars are allowed. NO body panels, scrapers, flaps, skirts of any kind or material, shall extend below the bottom frame rails on all four sides of the supermodified.
- 21 12 volt dry cell battery shall be allowed provided it is securely fastened to the frame inside the main frame rails and outside of the driver compartment and have a protective covering to prevent spillage of acid in the event of accident. The approval of the covering shall be determined by Oswego Speedway Tech.
22. No radio controlled, computer (controlled aided or activated), or computer recording devices of any kind, including traction-control devices (does not include Race Safe System.). No articulating chassis, body panels, or active suspensions allowed. Engine rev limiters that are only utilized to protect the

engine from over-revving are allowed, if they meet the following criteria. They must be: adjusted to a pre-set limit, not to be driver reachable or adjustable, and do not operate due to sensing a loss of tire traction, or control a loss of tire traction. **Tachometers with memories are allowed.**

23. Wide-five and six pin hubs shall be allowed on the front of the super-modified. On the rear six pin hubs, wide five hubs manufactured by Bicknell Racing Products (part #BRP 4304 and part #BRP 4307), wide five adapter plates manufactured from 6061 T-6 5/8 part # BRP-135 or equivalent shall be allowed. Splined rear wheels (e.g. Sander Engineering) are also allowed.
24. All supermodifieds shall be equipped with a working AMB transponder, while on the racing surface. The transponder shall be located at the right rear of the car, and be securely fasten to the frame or body panel. The transponder shall be mounted so that the front edge of the transponder is 140.5 inches behind the front edge of the front crash bar. The transponder shall have a clear view of the track, and not be mounted over frame members, suspension parts, or body panels.

ENGINE & GEAR SPECIFICATIONS

1. There shall be only one engine in a supermodified. It shall be an American made, cast iron, Chevrolet 427 c.i. or 454 c.i., Ford 429 c.i. or 460 c.i. or Chrysler 440 c.i. V-8 big block (including truck blocks) with 2 valves per cylinder and one spark plug per cylinder. The engine shall not exceed 470 cubic inches of displacement and shall have a minimum bore of 4.250 and the deck height shall be no lower than 9.750" on any engine. No reverse rotation engines shall be allowed. World Products aftermarket "Merlin" blocks allowed - parts #8010 & 8110 and 8111 cast iron, and Dart big M blocks allowed.
2. All competitors shall use an approved head for competition purposes. Aluminum heads shall be a standard engine manufacturer's type with standard engine manufacturer's valve covers, valve location, placement and standard intake port configuration. Valve angle maximum 2° rollover. The following list of heads, although non an all-inclusive list, ARE approved:
 - a) Chevrolet 3919836, 14011076, 14044862; Brodix BB2 thru BB2extra; DART 320, 360, Pro 1; WP020630-3&4; AFR 315 thru 357
 - b) Ford -M6049-A429, M6049-A460, M6049-B460 Aluminum Heads, Blue Thunder 429 and 460 Aluminum Heads.
 - c) Chrysler - Brodix B1 and B1BS Aluminum Heads, World Products 026040 & Indy-1, Indy-SR Aluminum Heads.
 - d) The following list of heads, although non an all-inclusive list, are specifically NOT approved: Chevy Pro Stock, Chevy Symetrical Bow-Tie, Dart Big M and Big Chief, Hemi, Chrysler 426 Hemi, A44 Hemi, Any overhead cam, Pontiac, Buick, Oldsmobile, Brodix-3, Brodix-4, Brodix-5, Brodix B1MC, Brodix B1TS, Indy-13, Mountain Motor or NHRA Pro Stock heads, Ford C-460, Ford D-460, and Chevrolet big block heads with evenly spaced intake ports or any head that has a raised intake port.

Any cylinder heads not listed above must be approved by tech inspector before being used in competition. All cylinder heads shall have standard engine

manufacturer's valve covers, valve angle, location, placement, and standard intake port configuration. No welding is permitted to raise the head runners, ports or intake manifolds which would allow or result in port relocation. A STOCK GASKET (e.g. MR. GASKET 121) MUST FIT INTAKE PORT/INTAKE BOLT PATTERN AND SHAPE. Manufacturer's identification number shall remain on the cylinder heads at all times.

3. The pistons shall be made of aluminum.
4. The crankshaft and connecting rods shall be made of steel only. A 1" DIAMETER INSPECTION HOLE on the bottom-left of the oil pan is MANDATORY. The inspection hole must be easily accessible, and afford a clear unobstructed view of the crankshaft and connecting rods. Engines without this inspection hole are subject to removal of oil pan for inspection of crankshaft and connecting rods.
5. No timed injection or injections identified as such shall be allowed. Turbochargers, superchargers, nitrous oxide and oxygen injection set ups shall not be allowed. Electronic fuel injection systems shall not be allowed. Only one injector nozzle and one injector line per cylinder. Only cast, one piece and three piece injection manifolds permitted. Fuel shall be injected through fuel injection system and not through head. No adapter plate or spacers between injection manifold and heads shall be allowed. Screen no larger than 1/4" shall cover top of injector stacks, to minimize foreign objects entering the engine.
6. All engines must be equipped with a magneto. If an external coil or spark box is used, it must be mounted in the engine compartment away from the cockpit and out of driver's reach when strapped in the car. Vertex, MSD, Mallory and Hunt units are allowed. No crank triggered systems allowed. TRACTION CONTROL DEVICES of any kind are NOT ALLOWED. Oswego Speedway reserves the right to inspect and/or confiscate any ignition parts at any time, providing there is just cause. Penalty for traction control use will be loss of points and one year suspension.
7. No ethylene glycol based antifreeze or coolants shall be allowed in radiator. Water Wetter and/or similar types of radiator additives are allowed. Water pump lubricants are allowed.
8. The lowest gear allowed shall be a **4:12**
9. **ALL METHANOL used by the supermodifieds at Oswego Speedway will be purchased from the designated Oswego Speedway fuel supplier, TO BE ELIGIBLE FOR POINT FUND MONIES.**

TIRE & WHEEL SPECIFICATIONS

1. The only tires allowed in competition shall be the following:

Left Front - Hoosier 11/24-15 Compound 2030

Right Front - Hoosier 13/25-15 Compound 2045

Left Rear - Hoosier 13/27 or 13/26.5-15 **Compound 2045 or M45**

Right Rear - Hoosier 17/28-15 Compound 2045

The price and availability are guaranteed throughout the racing season. (Availability means the specified sizes, e.g. 17/28-15 and compounds, and does not mean desired "chalk mark".

Tires must be purchased from the Oswego Speedway designated tire dealer.
No chemical treating of tires to soften compound.

Oswego Speedway officials reserve the right to examine, test, or confiscate any tire that is in question.

2. Before the heat races begin or at the conclusion of the heat races, the heat race starters or qualifiers shall report directly to the scales or other specified locations, at the discretion of tech. The left rear, right rear and right front tires shall be marked with a qualification stencil. At the conclusion of the consolation race, consolation qualifiers shall report directly to the scales. The left rear, right rear and right front tires shall be marked with a qualification stencil. All qualified cars **MUST** start the feature with those tires. If one of the stenciled tires is changed before the start of the feature for ANY reason, the car shall start at the back of the field. **Any tire change must be a previously stenciled tire and approved by a Tech Inspector. If time allows we will allow you to put 12 laps on a new tire before feature.**
3. During the feature race, a car shall be allowed to change any tire(s) which is completely flat, destroyed or unraceable, as determined by a tech inspector. More than one flat tire can be changed at one time.
4. All wheels shall be made of steel, magnesium or aluminum.
 - a) Minimum thickness for aluminum wheels shall be 3/16" (.187") with a 1/2" center section. Minimum thickness for steel wheels shall be .115" with a 3/8" center section that is at least 7" in diameter. Splined rear wheels are allowed.
 - b) No bead locking devices allowed.
 - c) No clip-on wheel weights allowed. The wheel weight shall be fastened inside the outer edge of the wheel and fully taped.
5. **All LR and RR tires must be picked up at the track the day of the race.**

BODY DESIGN AND DIMENSIONS

1. The wheel base of a supermodified shall not exceed 100 inches, measured from the center of the front axle to the center of the rear axle.
2. The maximum overall width of a supermodified shall be 85 inches, front and rear. This measurement will be made in the following manner. At the rear this measurement will be made using the Oswego Speedway measuring plates, in contact with the outer surface of the rim, outboard of the tire bead-mounting surface. At the front, the measurement shall be made at axle height, at the same outer rim surface. It is the team's responsibility to ensure this width is not more than 85 inches, no matter what front end geometry is utilized.
3. **No body panels or any other material shall extend below the bottom frame rails.**
4. **Wear or skid plates are allowed provided they are no thicker than 3/8" and no wider than 2"**

5. All body panels shall be made of metal or fiberglass. No Lexan, Plexiglass or transparent material shall be allowed, except for windshields.
6. The intent of these body rules is to provide for the construction of safe, aerodynamic and attractive supermodifieds. This is for the benefit of both the competitors and the spectators.□
5. FRONT SECTION: From the center of the front axle to the outermost portion of the front bumper.

a) Length of front section shall not exceed 34 inches.

b). Width shall not extend beyond the inside dimensions of the tires.

c). A single element nose wing may be used. The wing can't be wider than the inside of the front tires, no higher than the bottom of the front bumper and must be behind the leading edge of the front bumper.

d). Front bumper is mandatory. The bumper shall be at least 12" wide (at its narrowest point) and no wider than 16". The bumper shall be at least 3" high. It shall consist of 2 hoops with at least 2 front verticals. The bumper shall be constructed of 1" O.D. and .065" wall thickness or larger . All bumpers shall be mandrel bent to prevent sharp corners. The top loop of the bumper can be no lower than 13" and no higher than 22" from the ground. The lower loop of the bumper shall be no higher than 10" from the ground. If a jacking device is used it may be no longer than 2" and must point straight down.

e) Height of the front section shall not exceed the height of the top of the left front tire, measured from the ground to the highest body panel.



f) Body sheet metal shall be a single plane surface.

g) The front body panel or nose piece shall not be lower than the belly pan of the car.

6. CENTER SECTION: Area from the center of the front axle to the center of the rear axle.

a). Hood height shall not be higher than 2" above the steering wheel. The hood can be no wider than the outside dimensions of the chassis. A shroud to cover the throttle linkage can be used, but may not cover the sides of the intake manifold.

b). A Lexan or similar material windshield can be used providing it is not wider than the roll cage and is no higher than 5" above the steering wheel.

c). Side body panels shall be no higher than shoulder level of the driver while the driver is strapped in the seat. The driver shall have a minimum of 135 degrees of unobstructed vision on each side while strapped in the seat. No

sheet metal shall extend into the cockpit beyond the inside dimensions of the upper frame rails.

d) Right side body panels may extend to the inside dimensions of the tires. (the inside dimensions of the tires is measured by drawing a line from the inside of the front tire side wall rearward to the inside of the rear tire side-wall.) The vertical panels may not be higher than the side cockpit panels and cannot obstruct the drivers vision. If a horizontal panel is used, it must follow the contour of the lower right side frame rail with a 1" tolerance and be a solid 1 piece panel with no openings. The front and rear edges of the panel may be reinforced for strength.

e). Left side body panels may extend 6" beyond the inside edge of the left side tires. These panels may extend further to protect the oil tank and/or oil cooler but not further forward than the rear of the engine or beyond the nerf bar. If a horizontal panel is used, it must follow the contour of the lower frame rail with a 1" tolerance. This horizontal panel may have cut outs for oil coolers or other components.

f). No body panels can be attached to the roll cage above the drivers shoulders with the exception of securing the rear body work to the chassis.

g). Nerf bars are mandatory on both sides of the car. It shall be made of steel only (mild steel is acceptable) with a minimum of 1" O.D. and a minimum of .065" wall thickness. The nerf bar shall extend to within 1" of the outer edge of the tire, but can't extend beyond the outer edge of the tire. The nerf bars must not be further than 10" from the face of the tires and shall be at a height the same as the centerline of the axles. Each nerf bar must be attached to the chassis a minimum of 4 locations. Nerf bars must be attached to the chassis at the front, rear, and 2 positions at the center bulk head, (the bulk head behind the engine that the drivers legs go through)1 to the upper frame rail and 1 to the lower frame rail. This configuration will help protect the driver in case of a side impact and prevent the nerf bar from bending or deforming as a result of side impact which will protect the driver

h). All supermodifieds must have a continuous (1 piece appearing) flat belly pan,that will be attached to the bottom of both the left and right frame rails. The belly pan must extend the entire length of the center section, from the center line of the front axle to 18" beyond the center line of the rear axle. The belly pan can be no higher or lower than the bottom of the lower frame rails. A belly pan is also required under the engine. This pan must hold the entire liquid contents of the engine. A fire proof absorbent pad in the bottom of the belly pan is recommended to prevent a car from sliding on its own liquid.

i). Under chassis tunnels are not permitted

7. REAR SECTION: Area from the center of the rear axle to the outer most portion of the rear bumper.

a). Length of the supermodified body shall not exceed 40" from the center line of the rear axle.

b). Rear height shall not exceed 36" from the ground with the driver sitting in the driver's seat. This includes all body panels and fuel tanks, but does not include the head rest. A head rest is mandatory, but may not be higher than the top of the driver's helmet.

c). Body panels may extend from the front edge of the rear roll bar uprights to the front edge of the rear wing, (with the exception of the fuel tank container which may extend to the trailing edge of the rear wing). The panels

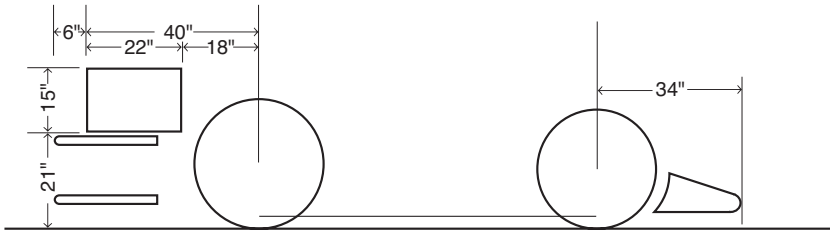

cannot be taller than 36" from the ground with the driver in the driver's seat and cannot be wider than the rear bumper excluding rear wing end plates and rear wing support panels which may extend to the inside dimensions of the rear tires.

d) The overall maximum outside to outside width, of the rear (tail) section shall not exceed 50 3/4 inches. This includes, but is not limited to, all parts and materials, such as: tail side panels, stiffeners, angle bends, fasteners, supports, mounts, wing, and non-wing structures. The 50 inches shall be measured from the outermost point toward the right rear tire inner sidewall, across the car towards the left side of the car. Note: If the distance between the rear tires is less than 50 inches, All tail sections if overlapping the left rear tire, must have their starting point within 1 inch of the inner sidewall of the right rear tire.

e). Rear wings may be used and may be free standing. The wings may not be movable while the car is on the racing surface. Any design or combination of wings may be used, up to 3 elements. The combination of wings must fit within the 22"long x 15" deep imaginary box.

f). The lower body work (under the fuel cell) must follow the contour of the bottom of the fuel cell and cannot create a tunnel.

g). A rear bumper is mandatory. The bumper may extend rearward 46" from the center of the rear axle, but must extend rearward at least 40" from the center of the rear axle. The bumper shall consist of at least 2 hoops and be

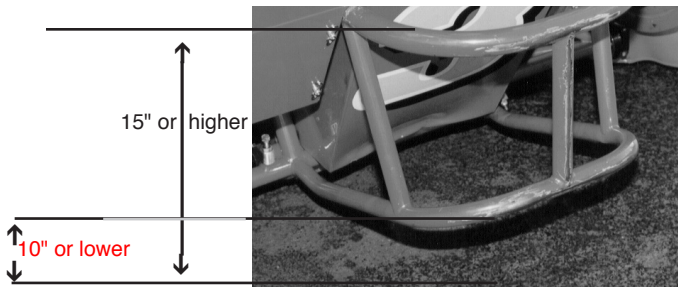

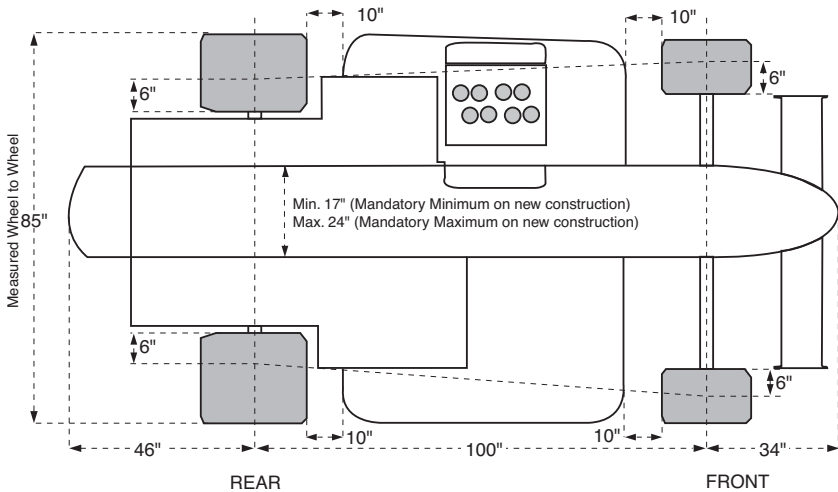

constructed of a minimum of 1" O.D. and a minimum of .065" wall thickness. The bumper must be mandrel bent and have a minimum of 2 vertical tubes made from the same material. The lower hoop of the bumper may be no higher than 10" from the ground. The bumper shall be a minimum of 16" wide, but no wider than 24".

h) Inner and outer, left and right side body panels, at the back of the roll cage and shall not exceed 36 inches in height. The driver shall have a minimum of 135 degrees unobstructed vision on each side of the cockpit (270 degrees total) while strapped in the car's seat with the side body panels in place. No panel shall extend into the cockpit beyond the upper cockpit horizontal frame rails. THE DRIVER MUST BE ABLE TO ENTER AND EXIT THE CAR FREELY, on both the right and left side of the cockpit. The side body panels shall taper down to below the level of the top of the left front tire at the center of the front wheels. THE ENTIRE DRIVER'S HELMET, when viewed from the same height, must be visible from outside the car, (Above the inner and outer body panels on both sides of the car), with the exception of the area blocked by the headrests. DO NOT RESTRICT THE DRIVERS VISION.

i) No in-cockpit adjustments allowed except for brake bias and fuel adjustments. This includes weight-jacking devices and adjustable shocks controls. (Adjustable shocks are allowed on the car but cannot be adjusted from inside the cockpit)

8. No roll cage mounted wings shall be allowed.
9. Full body panels shall be in place at all times while on the racing surface unless given approval by tech inspectors.
10. Body panels shall be changed or altered if tech inspectors feel there is a safety, visibility or rules compliance problem.
11. The intent of these body rules is to provide for the construction of safe,

aerodynamic and attractive supermodifieds. Any car owner whose car does not fit this description shall be asked to make the necessary changes by tech inspectors.

12. All supermodifieds shall be neat in appearance, professionally painted with large and legible numbers of contrasting color displayed on the front nose, sides and rear of tail section. Minimum size numbers on the tail end of a supermodified shall be 12 inches high and not obstructed from view by rear bumper. Gold or silver numbers on dark colored cars shall have a white or light colored background.
13. "For Sale" signs and any graphics which race officials deem to be in poor taste shall not be allowed on any supermodified body panel.

BRAKES

1. Any brake manufacturer may be used.
2. Dual master cylinders are mandatory.
3. All cars must have 4 wheel disc brakes with 1 caliper and rotor on each wheel.
4. Rotors must be magnetic steel or iron only. Rotors may be ceramic coated for improved wear and stopping power.
5. Brake lines must be steel or stainless covered Teflon.

FUEL BLADDERS AND FUELS

1. All supermodifieds shall be equipped with an approved fuel bladder. No hard rubber bladders or plastic cells allowed. All bladders must be fully enclosed inside a metal container. The fuel bladder container must be completely sealed to prevent fuel leaks in the event of a bladder failure. All fuel bladders must be above the bottom frame rails.
2. All bladders must have an aircraft type flush mounted fuel cap. No flip type caps permitted.
3. All fuel cells shall have an approved check valve vent that will prevent the loss of fuel if the vehicle is involved in an accident. No homemade vents or check valves are permitted.
4. Electronic fuel pumps that supply fuel directly to the engine are not permitted. Electric or mechanical fuel transfer pumps are allowed. If an electric pump is used, it must have a clearly marked switch on the dash board.
5. Front, rear or left side fuel bladders may be used.
 - a). The left side bladder cannot extend beyond the inside dimension of the left side nerf bar and must be located between the rear of the engine and the front surface of the left rear tire. The fuel bladder and container cannot be higher than the side body panels.
 - b). Front fuel bladders must be located inside the frame rails and be adequately protected from all suspension and steering components, engine heat and exhaust header heat.
 - c). Rear bladders must be protected by either the frame or the bumper.

6. 100 % methanol is the only fuel allowed with no additives except valve train lube providing it doesn't enhance the specific gravity of the methanol.

GENERAL SUPERMODIFIED COMPONENTS

1. The supermodified can be weighed either with or without the driver. The supermodified must weigh a minimum of 1825 lbs. after the race without the driver or 2025 lbs with the driver. The maximum left side weight allowed after the race is 68%. No fuel, water, oil or weight of any kind can be added before the car is weighed.
2. Bolt on weight is permitted, provided the weight is securely bolted to the chassis. Weight cannot be bolted to nerf bars or bumpers. Weight can't be placed on or inside the nerf bars. Lead shot is not permitted.
3. All exhaust pipes must run into a common collector for each side. Headers may be made of either steel or stainless steel.
4. All cars shall run a fully functional Schoenfeld muffler connected directly to the ends of the collectors. Either a 10" or 11" is acceptable. No other muffler is acceptable.
5. Carbon fiber components are allowed only to provide for driver safety. Carbon fiber cannot be used in place of metal for body panels or chassis construction.

ROLL CAGE SPECIFICATIONS

1. Supermodified cars shall be equipped with a roll cage that cannot encroach upon an imaginary cylinder extending upward from the cockpit opening. A 17-inch minimum is required on new construction in the rear hoop area in case a backboard has to be used to safely remove the driver.

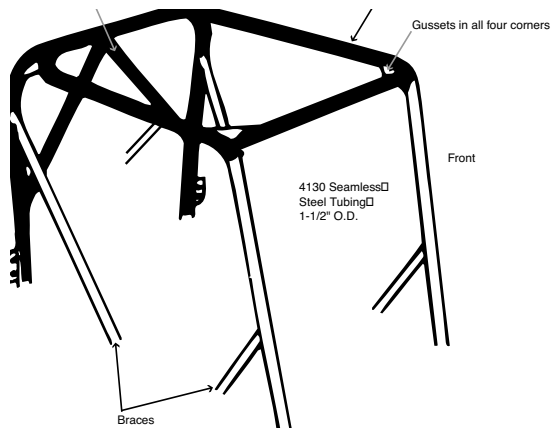

2. The roll cage shall be incorporated as part of the frame construction and shall be adequately braced to secure it in an upright position. The roll cage uprights shall extend to the bottom frame rail on all new construction.
3. A 2 ½ INCH DISTANCE SHALL BE REQUIRED FROM THE TOP OF THE UNPADDED HORIZONTAL ROLL CAGE BARS, TO THE TOP OF THE DRIVER'S HELMET, DIRECTLY BELOW THAT POINT WITH THE DRIVER STRAPPED IN THE SEAT, AND THE REQUIRED SEAT PADDING IN PLACE. An Oswego Speedway measuring device shall be utilized to ensure this minimum head clearance is met. Non-compliance will require the seat to be lowered, or an extension added to the roll cage, in order to comply with the rule. A four (4) inch distance between the top of the driver's helmet and the bottom of the horizontal roll cage bars is highly recommended.
4. The roll cage shall be constructed of material comparable to or of SAE 4130 seamless steel tubing with a minimum O.D. 1 1/2 inches and a minimum wall thickness of .095. The intersections of the cage tubing, at all four corners, at the top of the roll cage shall be gusseted, using a piece of tubing (at least 1 inch O.D.), welded a minimum of 3 inches from the intersections of these tubes. The roll cage shall be gusseted using a piece of steel tubing, (at least 1 inch O.D.), welded 3 inches from the intersection of the roll cage posts, and the upper frame rail on all 4 corners cage, on cars that have roll cage posts welded to the top of the upper frame rails.
5. A brace made of the same material (1 1/2" x.095) as the roll cage shall be welded on both the left and right side rear roll cage verticals and the top frame rails behind the roll cage. The brace shall be welded with the top of the tube at least halfway up both roll cage verticals (measured from the top frame rail just behind the roll cage to the top of the roll cage) and extend down to the top frame rails, behind the roll cage at an angle which adequately supports the roll cage post. This rule will be enforced on all new construction. 6. No sharp edges shall be left anywhere on the roll cage. **A brace made of the same material (1 1/2 x .095) shall be welded on both the left and right side rear roll cage verticals at an angle which adequately supports the roll cage**

post. The top of the tube must be at least 60% of the distance up from the bottom rail. This rule will be enforced on all new construction.

7. The roll cage shall be equipped with a V-type or X-type brace at least 1 inch behind the driver's head.
8. There shall be no sheet metal on the roll cage whatsoever.
9. Safety approved and manufactured (i.e. Simpson, Longacre, Moroso, Kirkey) roll cage padding shall be used around all of the horizontal and rear vertical roll cage bars, and any other roll cage bars or objects which may come in contact with the driver's helmet in the event of an accident. The padding shall be securely fastened using glue, tape etc. and may be covered with an upholstery type material (The blackened area in the roll cage drawing indicates where safety-approved padding may be placed.)

CHAPTER SEVEN

2012-13 SMALL BLOCK SUPERMODIFIED CAR SPECIFICATIONS

(Note: The term OEM (Original Equipment Manufacturer) refers to parts produced for stock passenger cars.

ENGINE SPECIFICATIONS

1. Block - Only American manufactured V-8 engine block shall be allowed with a standard displacement of 350 cubic inches for a Chevrolet, 351 cubic inches for a Ford and 360 cubic inches for a Chrysler. The block shall be cast iron OEM stock built for conventional passenger car use. No bow-tie blocks allowed. Castings and fittings shall not be changed. No machine work on outside of block or on front or rear of camshaft. Overbore of .060 to Chevrolet and Ford cylinders and .010 to Chrysler cylinders shall be allowed for a maximum displacement of 363 cubic inches. The engine shall be mounted in the standard position.
2. Cylinder Heads - Chevy SB World Products S/R Torquer Part #042660-1 or #042660-2, Ford SB World Products Windsor Jr. Part #053030-1 or #053030-2. Chrysler 360 c.i. block OEM head shall be used. All casting marks and numbers shall remain untouched. No sandblasting, bead blasting, porting, polishing, CNC work, radiusing or welding of heads. Heads may be milled to bring combustion chambers to minimum 60cc for Chevy or Chrysler and 58cc for Ford. Damaged or worn seats or valve guides may be replaced/repaired to return the head to its "STOCK CONDITION" as manufacturers intent.

VALVE SEAT WORK

This work may be accomplished with stones□ or carbide cutters or bowl hawks, but these□ tools **SHALL NOT BE RADIUSED**. The Angles □ Must Be Kept Sharp!

INTAKE

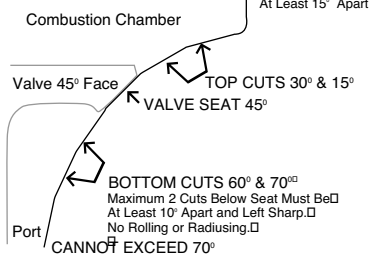

□**EXHAUST: May be multiple angles or radiused**

Heads can be purchased bare or assembled by World Products, Inc. Assembled heads include stainless steel valves, umbrella seals, heavy duty 1.250" diameter springs, 7 degree retainers & locks and screw-in rocker arm studs. Heads must remain stock as manufactured by World Products, with the exception of the allowed head milling, or repairing as mentioned above.

3. Carburetor - One (1) Holley #4412 carburetor (500 cfm, 2 barrel) maximum allowed. Carburetor shall be naturally aspirated and maintain stock venturi and throttle bore dimensions. Carburetor shall remain stock with the following exceptions: choke plate may be removed, main metering jets may be changed, power valve may be changed, accelerator pump may be changed and accelerator pump discharge nozzles may be changed. No cutting or polishing allowed. No electric fuel pumps allowed. No changing of carburetor metering blocks. The carburetor shall face forward, air horn to the front. Body panels shall not direct air into air cleaner. Air cleaner shall be no higher than seven inches (7") above the base of air horn of carburetor. No ram, bug catcher, or scoop-type air inlets, or air cleaner housings are allowed.

4. Intake Manifold - Only approved Edelbrock Performer intake manifold as specified below shall be allowed. The manifold shall remain untouched - no porting, gasket matching, painting or coating allowed. All fittings shall remain air tight. Air entering the manifold shall enter through the venturi of the carburetor only.

Chevrolet - #2101 Chrysler - #7176 Ford - #2181

5. Adapter Plate - A maximum one inch (1") adapter between the carburetor and manifold is allowed. Plate shall have two separate straight-through holes with a maximum diameter of 1.925". No radiusing, wedging or chamfering allowed.

6. Pistons - Flat top aluminum pistons with a maximum overbore of .060" for GM and Ford engines and .010" for Chrysler engines. No superlite or ultralite pistons allowed. No milling to lighten pistons allowed. Standard wrist pins only.

The following is a partial listing of approved pistons:

Wiseco - Chevy K011 Series / Ford K099 Series / Chrysler K234 Series

Ross - Chevy 94455/90455/91455/93455 / Ford #80555 for 4.030" bore / Chrysler Part #16-10 (Custom)

TRW - LW5005F/LW5006F/LW2256F

J-E - 1309 Series

Arias - E7057-030/040/060

Any other pistons must be approved by the Oswego Speedway technical staff.

7. Connecting Rods - Standard OEM forged large journal rods in standard size for type of engine (Chevy 5.7", Ford 5.954", Chrysler 6.123"). Manley sportsmaster connecting rod (part #14101) and Crower Sportsman (part #SP-91205) for Chevy engines shall be allowed. Any other I-beam rod must be approved by the Oswego Speedway technical staff.

8. Crankshaft/Dampener - Stock OEM, or exact aftermarket replacement, cast iron or forged steel crankshaft for the type of engine used is allowed. No lightening, polishing or knife edging allowed. A stock OEM, or exact aftermarket replacement vibration dampener/harmonic balancer shall be used.

9. Camshaft - Any hydraulic or solid lifter camshaft shall be allowed. No overhead or roller cams allowed. No gear drive or belt drive cams allowed.

10. Lifters, Rockers & Valves - Hydraulic lifters or solid lifters shall be allowed. Lifter bores shall remain OEM stock. No roller or mushroom lifters allowed. Roller rockers shall be allowed but no shaft type rockers, unless OEM stock. Screw in studs allowed, but no stud girdles allowed. Valve seat sizes (Chevy 2.020"x1.600" and Ford 1.940"x1.600") shall remain standard for head used. Valve stem diameters shall maintain these sizes. No undercutting of valve stems. Maximum 1.450" diameter valve springs allowed. 10 degree locks allowed. Absolutely no titanium or carbon fiber components of any kind used in engine including retainers, rockers and valves. No lash caps on valves allowed.

11. Exhaust Headers and Mufflers - All exhaust pipes shall run into a common collector on each side and shall run away from the cockpit of the car on each side or out the right side. The exhaust pipes shall also be located away from areas of possible fuel spillage. No 180-degree (interconnected)

headers, zoomie / grass burner headers or adjustable headers allowed. All cars shall run a fully functional approved Schoenfeld #83030 muffler, 8 inch minimum, unaltered from the manufacturer - . No homemade muffler or baffle systems allowed.

11. Exhaust Headers and Mufflers - All exhaust pipes shall run into a common collector on each side and shall run away from the cockpit of the car on each side or out the right side. The exhaust pipes shall also be located away from areas of possible fuel spillage. No 1800 (interconnected) headers, zoomie / grass burner headers or adjustable headers allowed. All cars shall run a fully functional approved Schoenfeld #83030 muffler, 8 inch minimum, unaltered from the manufacturer - . No homemade muffler or baffle systems allowed.

12. Oil System& Pan - Competition and claimer series wet sump oil pans shall be allowed. No power pans allowed. A 1 " INSPECTION HOLE IN LINE NWITH THE ROD THROW IS MANDATORY IN ALL OIL PANS. .A 2" x 3/4" skid plate shall be allowed behind the left front and right front tires to keep oil pan off of the racing surface Approved Oil Pans - Canton: Chevy 11-200, 11-102, 11-120, 11-122, 11-142, 11-210, 11-222, and 11-224. Chrysler 11-500, 11-510. Ford 11-650. Champ Pans: Chevy CP40, CP100, CP100LT, CP106LT, CP 57 & CP57LT. Ford CP351.

C-Line: Chevy 10071SB, 10074SB, 11000SB, 11001SB, 11002SB, 11100SB, 11011SB. Chrysler 10310 Mopar. All other manufacturers' oil pans must be approved by the Oswego Speedway technical staff.

No dry sump systems allowed. Oil catch can from front breather permitted. Oil cooler is permitted, but shall be mounted inside sheet metal and away from cockpit. No crank scrapers allowed.

13. Cooling System - Only one (1) radiator permitted and shall be centered in front of engine. No auxiliary cooling tanks allowed. No ethylene glycol based antifreeze or coolant allowed in radiator. Motor Max and water pump lubricants are allowed. Electric fan shall be allowed. Cooling system shall have a one gallon can or recovery unit located inside sheet metal and away from cockpit. Stock type water pump only. A fan shroud must be in place if car enters race track without a hood.

14. Ignition System - Any 12 volt ignition which is mechanically driven in stock position shall be allowed. No crank trigger systems. One (1) working coil only. No magnetos, boosters or other devices. Self starter and 12 volt battery are mandatory. Battery shall be securely fastened with steel straps to the frame inside the main frame rails and outside of the driver's compartment and shall have a protective covering. No traction control allowed.

CHASSIS/SUSPENSION/COMPONENTS

1. Factory Production Frame – NO NEW CONSTRUCTION FACTORY PRODUCTION FRAMES ALLOWED. The only small block supers allowed with STOCK FRONT CLIPS, are those appearing at the track in 2007 or before. See Tech for a list of Grandfathered cars.

a) Starting at the front to a point behind the rear most vertical roll cage tube, the lower frame shall not be cut or altered in any way from stock. Starting

at a point behind the rear most vertical roll cage tube, the lower frame rails shall be constructed of 2"x2" box tubing minimum wall thickness of .095." This tubing shall run to the back of the fuel cell and behind the fuel cell to join the two lower frame rails.

- b) Lower frame shall not be widened or narrowed and shall be full and completely parallel on both sides.
 - c) Cross members on lower frame may be notched for shock, spring and radiator clearance only.
 - d) Upper frame rails and vertical cross bracing shall be made of low carbon, mild steel tubing with a minimum O.D. of 1-1/2" and a minimum wall thickness of .083.
 - e) Tubular sub-frame is mandatory on the right side of the car, shall be parallel with the lower car frame at the kick out point and shall be constructed of the same material as specified in paragraph 1d above. If kick out frame is removed, the lower right sub-frame shall be constructed of 3"x2" .095 low carbon, mild steel box tubing.
 - f) No Jeep, Bronco (etc) or 4 wheel drive cars allowed. No sports car frames allowed. No front wheel drive or strut cars allowed.
2. Fabricated Front Frame - Fabricated front clip may be used as a replacement for stock front end. See schematic, photos and specs on page 35. Main frame rails shall be made of 2"x3" low carbon, mild steel box tubing with a minimum wall thickness of .095". Main frame rails shall remain parallel.
- a.) Overall width shall be 31" and overall length shall be 44." Maximum distance from centerline of front clip to the outside of the left main frame rail shall be 29".
 - b.) Stock Ford lower control arms (Part #F7AZ 3078A RH, #F7AZ 3079A LH / 1980 - 1997), or (Part # XW1Z3078CA right, and # XW1Z3079CA left) shall be installed on the fabricated front clip IN STOCK LOCATION (65 degrees to the center cross member - see diagram).
 - c.) Left main frame rail cannot be replaced, narrowed or widened. However, rear wheel spacers and replacement of rear axle tubes shall be allowed to accommodate frames which are narrower than fabricated clip. Spacers or axles tubes shall not allow offset.
 - d) A bolt-on front clip is allowed, but the bolt-on section must be in front of all "A" arm mount points.
3. Full Fabricated Frame - Using fabricated front clip (2 above). Left main frame rail shall be made of 4"x2" or 3"x3" low carbon, mild steel box tubing with a minimum wall thickness of .095". Starting at a point behind the rear most vertical roll cage tube, the lower frame rails shall be constructed of 2"x2" box tubing with a minimum wall thickness of .095". This tubing shall run to the back of the fuel cell and behind the fuel cell to join two lower frames. No bolt-on rear clips allowed.
4. Suspension - Front suspension and steering shall be OEM stock and parts shall be replaceable by OEM stock parts. No straight axle front end. Center link may be steel after market.

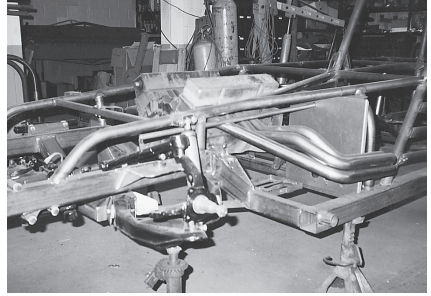
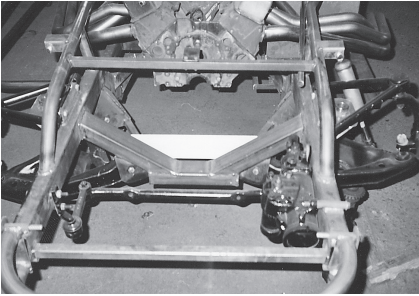

Small Block Supermodified using full fabricated frame.

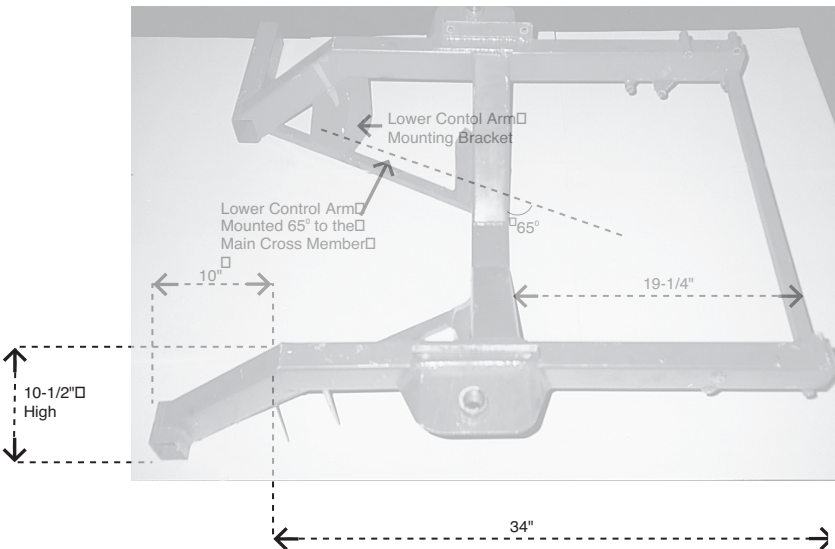
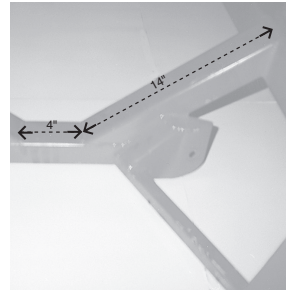
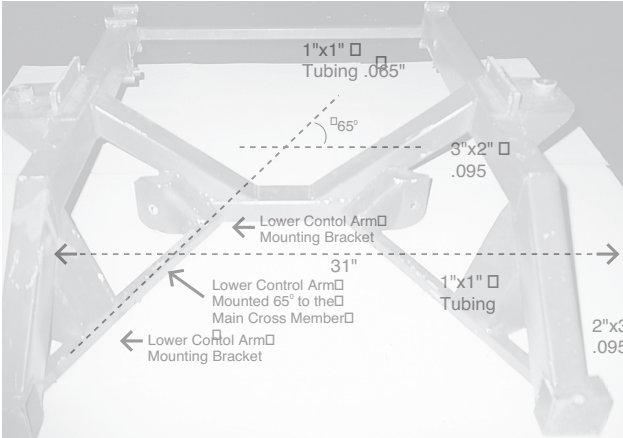

- a) Lower front A Frames cannot be altered, lightened or moved. Shall be OEM stock type in stock location.
 - b) Upper front A frames may be after-market tube-type and can be moved. Anti-sway bar allowed.
 - c) Stock passenger car spindles or after-market spindles allowed, but must be made of steel. Sweet Spindles
 - # 701-217-262, AND # 701-217-263, or comparable Coleman, or Troyer are allowed. No homemade spindles allowed. All spindles must be used in conjunction with Rule Book Legal "A" arms, hubs, wheels, and frame mount points, to ensure overall width of limited super is not more than 83".
 - d) Coil over shock assemblies must be used for rear suspension. The Centerline of the lower shock mounting point must be within 6" of the centerline of the rear axle. No coil overs on front allowed. No torsion bar, bell crank, cantilever or leaf spring suspensions allowed.
 - e) Rear of frame may be altered to accept coil over shocks and springs. Panhard rod may be used on rear only. No torque arms or traction devices of any kind allowed in the rear. The 3 point rear suspension shall be solid and the length of the top link from the top of the center section forward shall not exceed 20". No in-car weight jacking devices or suspension adjusting devices allowed.
 - f) One steel, non-rebuildable shock absorber per wheel only. No custom valve shocks allowed.
 - g) No aluminum or fiberglass spindles or A Frames. The panhard rod, radius rods, rod brackets, sway bar arms, and adjustable upper A-arm links may be made out of aluminum. No other suspension parts shall be made out of aluminum. No fiberglass suspension parts of any kind shall be allowed.
5. Rear End - Any quick change, non-quick change, passenger car or truck rear end may be used, but it must be a locked rear end. No aluminum allowed except for center section/spool. No open tube or magnesium rear ends allowed. No cambering of rear ends allowed. Non-floater passenger car rear ends shall have cover or other device to prevent axle from flying out in the event of breakage.
6. Steering - Steering box shall be stock type and shall remain in stock location. Power steering is permitted. **Rack and pinion steering will be allowed.** Tie rods may have steel heim ends. Tie rod sleeves shall be made of steel or aluminum tubing and cannot be slotted. Heim end should be run in sleeve at least 1 1/2 times the diameter of the heim end threads. Steering in the cockpit may be modified to suit driver's size and comfort, but shall be kept on the left side of chassis, centered to seat. No rear wheel steering or four wheel steering shall be allowed.
7. Transmission/Clutch - Only OEM production 3 speed manual transmissions shall be allowed with first, second, third, neutral and reverse gears in working order.
- a) The gear ratios are as follows: 1st gear - 2.5 times, 2nd gear - 1.5 times and 3rd gear - 1.0 times the rear end gear being used (Example: 1st Gear - 1,000, 2nd Gear - 600, 3rd Gear - 400).

- b) Transmission shall be clutch controlled. With engine running and the transmission in neutral, the driver strapped in the seat, the driver shall be able to engage the clutch and move the car both forward and backward.
 - c) Clutch unit shall be a single, dual or triple disc steel clutch with a minimum diameter of 7" and shall have a steel ring gear. Any clutch unit used shall have an explosion proof steel bell housing, or a shield built of at least 1/4" x 6" wide steel which covers the clutch area on a 360 degree pattern, securely anchored. No internal clutches or buttons allowed. No aluminum bell housing or aluminum scatter shield allowed. THERE SHALL BE A 1" DIAMETER HOLE IN THE TOP OF THE BELL HOUSING FOR CLUTCH INSPECTION.
8. Driveshaft - Driveshaft shall be made out of steel only and shall be painted white for ease of visibility should it become detached from the car. Medium duty (Series 1350) universal joints with solid cross are highly recommended on both ends of the driveshaft.
- a) Two drive shaft loops are required, They shall be constructed of at least 1/4" x 2" steel, and should be mounted no more than 6" back from front of drive shaft and 6" forward from the back of the drive shaft.
9. Brakes - Brakes shall be operating on all 4 wheels . No after-market brakes allowed. "Hawk" pads and high quality brake fluid, are highly recommended.
- a) Dual master cylinder is mandatory.
 - b) Brake calipers shall be made of steel. Calipers cannot be lightened and shall be OEM stock.
 - c) Rotors cannot be lightened or drilled. Rotors may be redrilled for different bolt pattern or larger studs.
 - d) No brake floaters shall be allowed.
 - e) Non-computerized brake re-circulating systems (e.g. DPI 2150 or 2160) are allowed.
10. Wheels & Hubs - 10" wide steel wheels with 3" offset/backspace shall be the only wheels allowed.
- a) No bead locking devices, including screws, allowed. No wheel discs or mud caps allowed.
 - b) OEM stock steel hub shall be allowed on the left front. After market steel safety hub (heavy duty steel hub, designed specifically for racing, and supplied by such companies as Troyer, Sweet, or Coleman, shall be mandatory on the right front and optional on the left front, with a minimum .810 thickness steel rotor. Steel hubs only may be used on rear of the car. No adapter plates allowed.
 - c) No spacers added between hub and wheel in the front.
 - d) Clip on wheel weights shall not be allowed. The wheel weight shall be fastened inside the outer edge of the wheel and fully taped.
11. Firewall/Floorboard - There shall be a fire wall between the engine compartment and cockpit and also between the cockpit and rear portion of the car where the fuel tank is located. The front and rear fire wall shall be made from at least 20 gauge steel and shall be adequately bolted or welded to the

frame rails. Additionally, the entire area separating the cockpit from the engine compartment shall be sealed to minimize burns of any type. Floorboards are mandatory and shall be made out of the same size material as the firewalls.

12. Belly Pan - The car shall have a removable belly pan which runs the entire length of the lower frame rails. This belly pan shall be of a size, shape and material capable of holding the entire liquid contents of the car's engine. There shall be a 1" inspection hole with a removable plug directly under the center of the harmonic balancer. Use of a fireproof absorbent pad is recommended. The belly pan shall be notched for skid plates if used (see rule #12, Oil System and Pan), or for an oil pan protecting cross member if used (see rule #5, Car Dimension & Body Design). The only parts of the car less than 3" from the ground would be: any of: the skid plates, the oil pan protecting cross member, or the belly pan directly under the oil pan.
13. Hook Loop - All limited supers shall be equipped with a hook, loop, or lift point located as near as possible to the center of gravity of the car, capable of supporting the entire weight of the car. The device/location shall be brightly colored and bolted or welded to the frame and of appropriate size and shape so the car can be lifted into the air by the tow truck. No muffler clamp-like devices allowed.
14. Computers - No radio controlled, computer controlled, computer aided, computer activated or computer recording devices of any kind, including traction control devices. No articulating chassis, body panels or active suspensions allowed. No fan cars or ground effects cars allowed.
15. Car Variations - No IMCA modifieds, sports modifieds, supermodifieds or cars identified as such shall compete with the small block super division.
16. Height & Weight - The small block super shall have a ground clearance of 3", as specified elsewhere in this book, at all times, and shall weigh no less than 2,350 lbs. with driver at all times. The top 5 cars shall go to the scales from the track after the feature race to be weighed. No fuel, or any other item, or material, shall be added at scales to make weight. If weight must be added, bolt on weight cannot protrude from frame any farther than 3" and shall be securely fastened. No filling of nerf bars or bumpers with any substance. Maximum left side weight shall be 57% of total with driver. No bolt on weight allowed in the cockpit (driver occupied area).
17. Bumpers - Front and rear bumpers are mandatory and shall be made of identical tubing. They shall be made of steel with a minimum O.D. of 1 1/2" and a minimum wall thickness of .083, and shall adequately protect body work from cutting another competitor's tires.
 - a) **Front Bumper** - It shall be two horizontal bars strongly fastened to the frame on the left and right side with at least two vertical cross braces. The height shall be 15" measured from the ground to the center of the bumper. It shall extend beyond all sheet metal body work, shall be as wide as the lower frame at the outermost point, shall have rounded corners and shall not extend beyond the inside dimension of the tires. The height of the front bumper vertical contact surface shall be a minimum of 6" tall, as measured from the top of the upper horizontal bar, to the bottom of the lower horizontal bar. The top of the upper bar shall be 18" from the ground and the bottom of the lower horizontal bar shall be 12" from the ground.

b) **Rear Bumper** - It shall extend outward to the outside edge of the rear tires and shall have rounded corners. It shall turn forward and inward toward the rear tires at a height of 15" measured from the ground to the center of the bumper. It shall be strongly fastened to a vertical brace welded to the upper and lower frame rails at a point no closer than 8" from the back of the rear tires in a lengthwise measurement. The back portion of the rear bumper shall have two horizontal bars connected with at least two vertical cross braces. The back portion of the rear bumper vertical contact surface shall be a minimum of 14" tall, in the area directly behind the fuel cell, as measured from the top of the top horizontal bar to the bottom of the bottom horizontal bar. The top of the upper horizontal bar shall be 22" from the ground and the bottom of the lower horizontal bar shall be 8" from the ground.

18. **Nerf Bars** - Nerf bars are mandatory on both sides of the car and on both rear corners of the car behind the rear tires. All nerf bars shall be made of identical tubing.

a) Left side and right side nerf bar shall be constructed using two pieces of mild steel tubing with a minimum O.D. of 1-1/2" and a minimum wall thickness of .083. The bottom rail shall mount straight out from the lower portion of the frame at the front and rear. The top rail shall mount straight out from the upper portion of the frame at the rear then radius down to the bottom rail in the front. The left side and right side nerf bar shall be mounted to the frame so that the top and bottom rails are centered with the centerline of the tires. There shall be a vertical brace of the same size material running from the top nerf bar rail to the bottom nerf bar rail near the rear radius. The nerf bar shall extend outward even with the outside edge of the tires and shall extend no closer than 8" from the front and rear tires in a lengthwise measurement. The distance between the top and bottom nerf bar rails measured from the center of the top rail to the center of the bottom rail shall be a minimum of 6" and a maximum of 10". Nerf bar rail distance, as described above, may taper from 10" in the rear to 6" in the front.

ROLL CAGE & COCKPIT SPECIFICATIONS

1. Small Block Supermodifieds shall be equipped with a roll cage that cannot encroach on an imaginary rectangular box extending upward from the cockpit opening. The rectangular opening shall be a minimum of 17.5" wide and 22" long.
2. The roll cage shall consist of a continuous rear hoop, and front cage posts that extend continuously back to join the rear cage hoop. The upper front cage posts shall be connected by a cross tube, located at the front of the cage opening. All other cage designs must be authorized by the tech inspectors on a case by case basis.
3. The roll cage shall be incorporated as a part of the frame construction and shall be adequately braced to secure it in an upright position. It is mandatory that the roll cage uprights extend to the lower frame.
4. The top of the driver's helmet shall be COMPLETELY BELOW the bottom of the horizontal roll cage bars after being wrapped with safety approved roll

cage padding. A four (4) inch distance between the top of the driver's helmet and the bottom of the horizontal roll cage bars is highly recommended. A 2 INCH DISTANCE SHALL BE REQUIRED FROM THE TOP OF THE TOP OF THE UN-PADDED HORIZONTAL CAGE BARS, TO THE TOP OF THE DRIVER'S HELMET, DIRECTLY

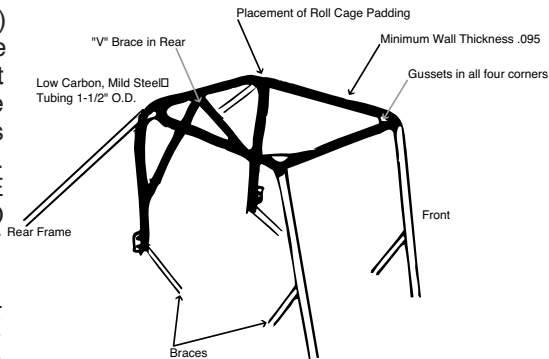

BELOW THAT POINT WITH THE DRIVER STRAPPED IN THE SEAT, AND THE REQUIRED SEAT PADDING IN PLACE. An Oswego Speedway measuring device shall be utilized to ensure this minimum head clearance is met. Non-compliance will require the seat be lowered, or an extension added to the roll cage, in order to be in compliance.

5. The roll cage shall be constructed of low carbon, mild steel tubing with a minimum O.D. of 1 3/4" and a minimum wall thickness of .095. The roll cage shall be gusseted using a piece of steel tubing welded 3" from the intersection of the roll cage and the upper frame rail on all four corners.
6. No sharp edges shall be left anywhere on the roll cage.
7. The roll cage shall be equipped with an inverted V-type or X-type brace behind the driver's head.
8. There shall be no sheet metal on the roll cage whatsoever.
9. A brace made of low carbon, mild steel tubing with a minimum O.D. of 1-1/2" and a minimum wall thickness of .083 shall be welded from the top of the roll cage on the back left and right corner down to the upper frame rail.
10. All cars shall have crash bar protection on the driver's left side made of the same material as the roll cage. At least four (4) bars shall be welded horizontally from the front of the roll cage to the rear of the roll cage with a minimum of two (2) vertical cross braces of the same dimension. All vertical bars or braces on the driver's left side shall be welded to the main lower frame rail. If they are welded to a side bar, then the side bar must be welded to the main frame rail in at least five places. The left side door bar area shall be covered on the outside, by a steel plate, with a minimum thickness of 0.095". The plate shall be welded to the door bars and shall cover the area from the left front cage post, to the left rear cage post, and from the lower left frame rail, to the top left door bar.
 - a) The area under the driver's seat shall be braced in such a way as to minimize the likelihood of an object puncturing the seat. The area should be X-braced, with a minimum tubing size of 1" OD x 0.095 wall thickness, or may be plated with .095 mild steel plate, to provide under the seat protection.
11. Construction of foot box and right side cockpit protection, including diagonal or cross braces shall be made of the same material as the roll cage.

12. Safety approved and manufactured roll cage padding (Kirkey, Simpson, Longacre, Moroso, and Rebo) shall be used around all of the vertical and horizontal roll cage bars, including the V or X type brace behind the driver's head. It shall be securely fastened using glue, tape, etc. and may be covered with an upholstery type material. (The blackened area in the roll cage drawing indicates where safety-approved padding must be placed).
13. Drivers Seat- SEE: Chapter 8 Rule 1

FUEL & FUEL TANKS

1. A 22 gallon rectangular fuel cell, fully enclosed inside a 22 gauge steel box is mandatory. No hard rubber or plastic cells allowed. No fittings or tubes from bottom of cell or case. Approved cells include ATL Super Cell, Sport Cell, Saver Cell, and Jaz Cell. ATL Racell Red and Racell Black are not approved cells.
2. Racing gasoline, as provided by THE DESIGNATED RACING GAS SUPPLIER at the Speedway shall be the only type of fuel allowed. No additives of any kind shall be allowed. The specific gravity of track supplied gasoline will be checked at each race event. Competitors fuel samples must be within +/- 50 points of the track test sample. Fuel not meeting this specific gravity range may lead to disqualification.
3. All cars shall use aircraft type fuel caps flush mounted on the top of the fuel tank.
4. There shall be an all metal check valve (e.g. KBP 70, or equivalent, designed for racing purposes), to prevent leakage from any fuel line venting to the atmosphere. This valve shall be installed, whenever possible, inside the fuel tank/cell. It is recommended if a vent line is used, it run to a higher point on the car (e.g. the protected side of the roll cage). It is further recommended that this hose loop around and continue to a location near the bottom of the fuel cell, away from the driver and heat sources.
5. Fuel cells shall be mounted in center of frame behind the rear axle using angle iron bolted or welded to rear frame. The fuel cell shall be completely within the rear frame rails protecting it on all sides and shall be bolted to the angle iron or secured using at least two (2) steel straps, 1" wide by 1/8" thick around the container and angle iron.
6. All Small Block Supermodifieds shall have a main fuel shut-off valve within easy reach of the driver, crew member or track safety crew, in the event of a major fuel leak.

TIRES & GEAR SPECIFICATIONS

1. Hoosier 9 tire (9/27-15) 700 compound on the RIGHT SIDE and a Hoosier 9 (9/27-15 or (9/26.5-15) 500 compound on the LEFT SIDE, mounted on a 10 wheel, shall be the approved tire and wheel combination in 2012. This change is being made in an effort to cut tire costs. No chemical treating of tires allowed. Tires must be purchased from the Oswego Speedway designated tire dealer.
2. The lowest gear that shall be used is a 4:37. The highest gear that shall be used is 4:00.

CAR DIMENSIONS & BODY DESIGN

1. The wheelbase of a limited super shall be a minimum of 108" and a maximum of 112".
2. The maximum overall width of the limited super shall be 83". This includes all portions of the car measured from the outer-most point on the left side tires to the outermost point on the right side tires.
3. All major components; engine, transmission, drive train, fuel cell, rear end center section and radiator shall be on the centerline of the lower passenger car frame, with no tolerance allowed.
4. Engine Location - Rear of engine (bell housing flange) shall be a minimum of 72" forward from the center line of the rear axle with no tolerance allowed. Engine shall be located a minimum of 10" from the ground to the center line of the crankshaft.
5. The small block super shall have a ground clearance of 3" on all four sides measured from the ground to the lowest part of the car. This includes such items as: frame structure, body panels, driveline, and exhaust. The oil pan shall be adequately protected by a "single oil pan protecting cross member", or by skid plates (see rule #12, OIL SYSTEM & PAN, which may extend below the belly pan to a point less than 3" from the ground. NOTHING shall extend below the floor/belly pan EXCEPT "the single oil pan protecting cross member".
6. Body panels shall be made of aluminum only, except fiberglass nose piece and cockpit body work shall be allowed. No body panels of any material shall extend below the lower frame on all four sides of the limited super.
7. FRONT SECTION- From center of front spring bolt forward to outermost portion of front bumper.
 - a) Length of front section shall not exceed 34".
 - b) Length of front sheet metal section shall not exceed 32."
 - c) Height of body sheet metal in the front section shall not exceed the height of the top of the left front tire, measured from the ground to the highest body panel. If the top of the radiator is higher than the top of the left front tire, the front section body work, from the spring bolt back to the radiator may incline upward, as high as the top of the radiator. (See picture of limited super on page 38). The continuation of this panel may provide a cover for the top of the radiator.
 - d) Width of body sheet metal may extend from the inside of the tire on the left side to the inside of the tire on the right side.
 - e) Body sheet metal shall be a single surface area. AIRFOILS ARE ALLOWED. WINGS ARE NOT ALLOWED. A WING SHALL BE DEFINED AS ANY DEVICE MOUNTED ON THE BODY, OR BUILT INTO THE BODY OF THE CAR, UTILIZING SEPARATE UPPER AND LOWER SURFACES (NOT A SINGLE PLANE SURFACE).
8. REAR SECTION- From center of rear end back to the outermost portion of the rear bumper.
 - a) Length of rear section shall not exceed 47".

- b) Rear height shall not exceed 36" without driver from the ground to the highest body panel and this height may extend only to the back of the roll cage. This includes all body work, but excludes headrests.
 - c) Rear body width shall extend from the right side to the left at a maximum of 60" and a minimum of 55" providing at least half (6") of the left rear tire is covered, (up to 1/2 (6") of the left rear may be uncovered). This measurement will be taken from the outer sidewall of the left rear tire.
 - d) Rear body sheet metal shall be a one surface, single plane area. The rear body panel shall cover the left rear tire and extend back to the rear of the tail section, to make the rear tail section a single surface. (see picture on page 38). When viewed from the rear, the rear "vertical" body panel, behind the fuel cell, must extend from the left frame rail, to the right frame rail, and from the lower rear cross member, upward to meet the full –width upper cross panel that forms the upper rear portion of the tail section. There shall be no holes, vents, or exhausts in the vertical panel.
 - e) No wings allowed. A wing shall be defined as any device mounted on the body of a car or built into the body of a car, utilizing separate upper and lower surfaces, (NOT A SINGLE PLANE SURFACE).
 - f) No holes or louvers will be allowed. All outer tail side panels shall be supported, as required, by small diameter tubes or equivalent (not larger than 1" OD). These supports shall be installed between the outer panels and the frame. If supports are needed on the 2 inner tail vertical panels, the same rules apply. No SCOOP or DEFLECTOR-STYLE shall be allowed as supports between any of the vertical tail panels, above or below the upper tail surface.
9. CENTER SECTION - Area between inner tread surface of front and rear tire on same side.
- a) The cockpit shall be on the left side of the car. The outside edge of the left rear roll cage loop shall be at least 4" in from the outside edge of the left rear tire. In addition, the outside edge of the left rear roll cage loop shall not extend outward any further than 6" from the outside edge of the lower stock passenger frame. No frame rails of any kind shall extend outward beyond the left rear roll cage loop on the left side of the car. Body panels on the left side of car shall not extend beyond the tubular frame and crash bars.
 - b) The right side body panels may extend beyond the tubular sub-frame, but may not extend beyond the inner sidewalls of the right side tires. An additional right side body panel may be added to the traditional body style providing it meets the following dimensions:
 - 1. The panel shall not extend beyond the inner sidewalls of the right side tires.
 - 2. The panel must be a single thickness, and remain open on the bottom.
 - 3. The panel may not extend lengthwise beyond the front and rear tires.
 - 4. The panel height in the back must be no higher than the right rear tire, and must taper so that the panel height in the front is level with the upper frame support tube.
 - c) Hood height from front of roll cage to center of front wheels shall not be

higher than 1" above the engine valve covers. Hood width shall fall within body measurements for left and right side of car as specified above. Aircraft quality (lexan) windshield may be used, but can be no wider or higher than the steering wheel.

- d) Inner and outer, left and right side body panels, at the back of the roll cage and shall not exceed 36". The driver shall have a minimum of 135 degrees unobstructed vision on each side of the cockpit (270 degrees total) while strapped in the car's seat with the side body panels in place. ONLY sheet metal approved by TECH shall be allowed to extend into the cockpit beyond the inside dimensions of the roll cage. DRIVER MUST BE ABLE TO EXIT THE CAR FREELY, on both the right and left side of the cockpit. The side body panels shall taper down to below the level of the top of the left front tire, at the center of the front wheels. THE ENTIRE DRIVER'S HELMET, when viewed from the same height, must be visible from outside the car. (e.g. above the inner, and outer body panels on both sides of the car), with the exception of the area blocked by the headrests. DO NOT RESTRICT THE DRIVER'S VISION.
- d) Inner and outer, left and right side body panels, at the back of the roll cage and shall not exceed 36". The driver shall have a minimum of 135 degrees unobstructed vision on each side of the cockpit (270 degrees total) while strapped in the car's seat with the side body panels in place. No sheet metal shall extend into the cockpit beyond the inside dimensions of the roll cage. DRIVER MUST BE ABLE TO EXIT THE CAR FREELY, on both the right and left side of the cockpit. The side body panels shall taper down to below the level of the top of the left front tire, at the center of the front wheels. THE ENTIRE DRIVER'S HELMET, when viewed from the same height, must be visible from outside the car. (e.g. above the inner, and outer body panels on both sides of the car), with the exception of the area blocked by the headrests. DO NOT RESTRICT THE DRIVER'S VISION.

10. No roll cage mounted wings allowed.
11. Full body panels shall be in place at all times while on the racing surface unless given approval by tech inspectors.
12. Body panels shall be changed or altered if tech inspectors feel there is a safety, visibility, or rules compliance problem.
13. The intent of these body rules is to provide for the construction of safe, aerodynamic and attractive limited supers. Any cars not fitting this description shall be asked to make the necessary changes by the tech inspectors.
14. All small block supers shall be neat in appearance, professionally painted with large and legible numbers of contrasting color displayed on the front nose, sides and rear tail section. Minimum size numbers on the tail of a limited super shall be 12" high and not obstructed from view by rear bumper. Gold or silver numbers on dark colored cars shall have a white or light background.
15. "For Sale" signs and any graphics which race officials deem to be in poor taste shall not be allowed on any limited super body panels.
16. TRANSPONDERS- All small block supermodifieds shall be equipped with a working transponder, while on the racing surface. The transponder shall be located at the right rear of the car, and be securely fastened to the frame or body panel. The transponder shall be mounted so that the front edge of

the transponder is 128 inches behind the front edge of the front bumper. The transponder shall have a clear view of the track below, and not be mounted over frame members, suspension parts, or body panels.

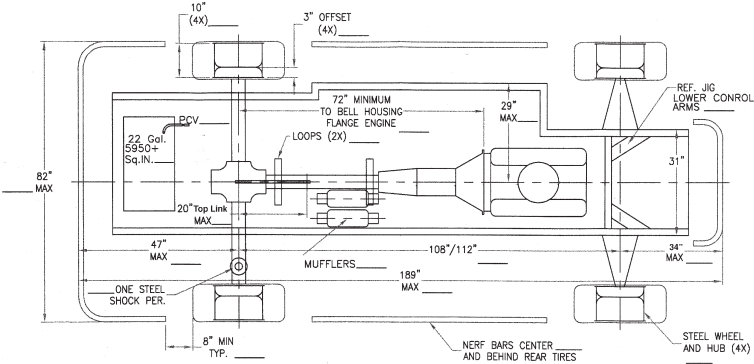

CHAPTER EIGHT

COCKPIT, DRIVER & PIT SAFETY -All Divisions

1. DRIVER SEAT - Driver seat shall be metal and provide support of both left and right sides from shoulders to the legs. Seat shall be mounted using a minimum of four grade 8 - 1/4" bolts (with large diameter washers between the head of the bolt and the seat surface), to the frame structure of the car, behind the shoulders, and below the bottom of the seat. No fiberglass or plastic seats.
 - a) Driver seat shall be padded.
 - b) Seat shall have right and left shoulder supports.
 - c) Seat shall have left and right padded head supports.

d) All supermodifieds must be equipped with a head rest. This head rest must be properly padded. The head rest must be constructed in a manner that it can't be manually moved or deformed in any direction. It is recommended that the head rest be removable to enable the driver to evacuate the cockpit.

- e. All areas of the upper roll cage that the driver's helmet could come in contact with, must be adequately padded with an approved roll bar padding.

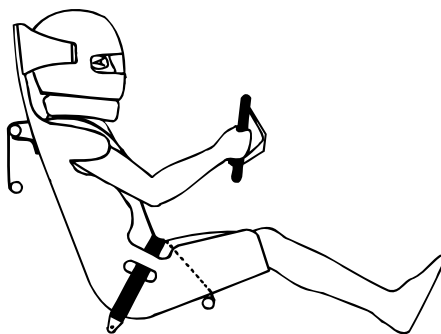

2. DRIVER BELTS - Three inch driver seat belts, shoulder harnesses and crotch (anti-submarine) belts are mandatory and shall be bolted or fastened to the frame. Each belt shall fasten separately to a common quick release type unit. Any belt showing wear or deterioration shall not be allowed. It is required that belts be replaced every two years. The complete belt assembly shall be worn at all times while the driver is on the racing surface. Separate shoulder strap fastening and sternum belt are highly recommended. Use the following illustration and recommendations for installing your belts: IT IS REQUIRED THAT NYLON WEBBED BELTS SFI SPEC 16.1 (SIMPSON, IMPACT, G-FORCE, ETC) BE REPLACED EVERY TWO YEARS. POLY-ESTER WEBBED BELTS -SFI SPEC 16.5 (WILLINS, SABELT, SCROTH, ETC) BE REPLACED EVERY 5 YEARS.
3. LAP BELT is designed to hold the lower abdomen, hip and pelvic area back into the seat and to provide the majority of control in holding your body down into the seat bottom. The lap belt shall be mounted at a 45 degree angle to the spine no matter what inclination your seating position provides. Always allow the lap belt to lie across your lower abdomen and route smoothly all the way around the hips to provide as much distribution of weight as possible. The crotch (anti-submarine) belt shall run from the common release unit, through the slot in the seat bottom, and attach to a frame member under the seat bottom. The lap belt shall not be routed over the top of the sides

of the seat. Lap belts are to hold your body, not the seat. It is important to route the lap belt through the slot provided in the seat, to provide proper distribution of pull.

4. **SHOULDER HARNESS** is the most abused belt in the harness system. Used improperly these belts will hurt you in a hard crash. Research indicates that back injuries (i.e. broken back, vertebrae damage from compression of the spine, tail bone breakage, etc.), shoulder and some neck injuries are directly attributed to shoulder harnesses being used improperly or improper seat design and not necessarily from the force of the impact itself. The main function of the shoulder harness is to hold your torso back into the seat. The shoulder harnesses shall be routed so they pass over the top of the shoulder and traverse at a 90 degree angle to the spine no matter what the inclination your seating position provides. This allows you to provide the proper tension required to hold your upper body back into the seat without taking your breath! The belts shall not run down your back below shoulder height before crossing through the shoulder harness slot in the seat and shall not run across the bony structure at the perimeter of the shoulder as damage will result. The shoulder belts shall be routed through the holes provided in the seat and across the cage tube to provide the best control of location of the belt.
5. Fuel shut-off valve and ignition switch shall be within reach of the driver when the driver is held into position by seat belts and harnesses. They shall be clearly marked "off" and "on", brightly marked and easily accessible by the safety crew.
6. All protrusions, brackets and bracing in the cockpit area (inc. roll cage) shall have smooth or rounded edges and if the driver is in close proximity to these items, (which could be contacted during an accident) they shall be protected with "ensolite" or equivalent material with a minimum thickness of 1/2 inch.
7. **All supermodifieds must have two (2) engine kill switches. One (1) must be located on the dash board and properly marked as such, and the other must be located on the throttle pedal toe strap. A throttle toe strap is mandatory and must connect to both left and right sides of the throttle pedal to ensure it will not bend or flex. Brake kill switches may also be used but aren't mandatory as they are less effective. L-shaped tow straps are not acceptable.**
8. Driver's vision shall not be obstructed by engine components, injector stacks, auxiliary fuel tanks, body panels, etc.
9. No mirrors shall be allowed.
10. The quick release part of the removable steering wheel shall be made of metal only.
11. Supermodifieds and small block supers shall have an on-board fire extinguishing system with a minimum 5 lb capacity. Actuating button shall be within driver's reach when strapped in the car. A minimum of 2 nozzles in the cockpit shall be directed toward lower part of the driver's torso and feet. Fire bottle shall have a gauge that is clearly visible, with the bottle installed in the car. Fire bottle actuator shall have a highly visible attachment (flag or decal) to readily identify its location. Pins shall be pulled from the system, (system shall be "armed") at all times when on the race track.
12. Radio communication between the driver and the pit crew or between pit

crew members is not allowed. Receiver only or scanner radios in direct communication with the Competition Director shall be mandatory for the supermodified, small block super divisions. The radios must be activated and in use at all times, including warm-ups.

13. The driver shall wear the following protective racing apparel:

- a) A full face helmet with proper fastenings and protective eye shield is mandatory. All helmets must be SNELL certified. In 2012 the helmet must have the Snell 2005 or 2010 rating. If the driver's helmet has been subject to impact as the result of a crash, being thrown, etc the driver shall provide written confirmation to the chief tech inspector, that the helmet has been inspected and approved for competition by the helmet manufacturer. Failure to do so shall result in confiscation of the helmet by the chief tech inspector.
- b) Nomex hood or "clava" if not built into the helmet.
- c) Fire retardant uniform (minimum double layer) properly fastened at neck, wrists and ankles.
- d) Fire retardant socks, underwear, gloves and shoes.
- e) All drivers must wear a HANS or HUTCHINS device while on the racing surface.
- f) Safety arm restraints are mandatory for supermodified and limited supermodified divisions.
- g) The chief tech inspector reserves the right to confiscate any safety equipment that is of a questionable nature.
- h) Any person being "pushed off" (starting a supermodified in the pit area), must be strapped-in and be wearing a helmet.

14. BATTERIES – 9 volt battery(s) is allowed in the driver occupied area. No larger, dry-cell type batteries, (Example, to power fuel pumps), shall be allowed in the driver occupied area of the car, or attached anywhere on the exterior of the car. All such batteries must be securely fastened within the main frame rails and body panels of the car. No wet cell batteries are allowed.

15. If a driver receives an injury requiring continuous medical attention from a physician or chiropractor, the driver shall be required to submit, in writing, a medical release on the attending physician's or chiropractor's letterhead and it shall be received by the Competition Director 24 hours prior to the next scheduled race meet in which the driver wishes to participate. Also, the driver shall demonstrate to the Competition Director the ability to enter and exit the car quickly and safely before being allowed to compete.

16. If a driver is rendered unconscious from an accident on the track, the driver, upon regaining consciousness, shall be unable to compete for the duration of the race meet.

17. Drivers shall be physically and mentally healthy in order to compete on any given race meet. The Competition Director may require a driver to submit a statement, in writing, on his attending physician's letterhead, attesting to the driver's fitness to operate a race car.

18. A driver, owner, crew member or pit pass holder, may be requested to submit to a drug or sobriety test, for any reason on or off the track, at the discretion of the Competition Committee. Anyone testing positive may suffer expulsion

from the track for a period of time to be determined or the remainder of season.

The Competition Director reserves the right to disqualify any driver deemed “unfit to race” by track medical personnel.

19. A driver refusing medical treatment must sign a medical waiver. Driver may not be allowed to compete for the remainder of the event at the discretion of the competition director.
20. All crew members shall be attired in a shirt and long pants only.
21. Each race team shall be equipped with a 5 lb. or larger, fully charged, dry chemical fire extinguisher in their pit at every race meet. The extinguisher shall be in plain view and easily accessible.
22. There shall be no gas stoves, barbeque grills or any other cooking units in the pit area.
23. All race teams must have a 5-gallon bucket of water readily available in their pit area.

CHAPTER NINE

PROTEST & VIOLATION OF CAR SPECIFICATIONS - All Divisions

1. Only a registered car owner with his car in attendance may file a protest.
2. A car owner may protest only one car per race meet.
3. The protest shall be filed, in writing, before the preliminary events begin.
4. The protest shall explicitly state the car being protested and the particular specification that is being violated.
 - a) VIOLATION OF: TOTAL WEIGHT, LEFT SIDE WEIGHT, and ENGINE CUBIC INCH, SHALL BE GROUNDS FOR IMMEDIATE DISQUALIFICATION.
 - b) USE OF TIRE SOFTNER OR TRACTION CONTROL WILL BE GROUNDS FOR NO LESS THAN 1 YEAR SUSPENSION OF CAR OWNER AND DRIVER.
5. The person protesting shall sign the protest form and post \$200.00 Protest Fee per violation for the supers and \$100.00 Protest Fee per violation for the SBS. Engine protest fees shall be \$500.00 for supermodifieds and \$250 for SBS.
6. If the car under protest is in violation of the cited car specification, the Competition Committee reserves the right to allow sufficient time for changes to be made. The protest fee shall be returned to the car owner filing the protest.
7. If the car under protest is not in violation of the cited car specification, the protest fee shall be forfeited and paid to the owner of the car under protest.
8. All cars shall be measured and/or visually inspected each week by a qualified technical inspector to make sure they conform to car specifications.
9. After inspection, if there is a violation, the car owner shall receive a "Report Form" specifying the technical inspector's findings. The Competition Director shall also receive a copy of each Report Form issued.
10. The Report Form shall include the car being inspected, which of the car specifications are in violation, why the car does not conform and how long the car owner has to make the necessary changes. If a violation is deemed to be performance-enhancing by tech inspectors, the car owner is immediately subject to one or more penalties at the discretion of the Competition Committee.
11. On subsequent race meets, the technical inspector shall follow up on all violations not deemed to be performance-enhancing. If the necessary changes are not made within the specified time period, a monetary fine and/or point penalty shall be levied against the team as determined by the Competition Committee.

POST-RACE INSPECTION - All Divisions

1. Two cars chosen at random by the chief tech inspector shall be subject to a tear down inspection at the end of the feature race.
2. A sufficient cool down period shall be allowed for each car before the inspection begins.
3. The car shall be pushed into the tech building and a maximum of three crew members shall be allowed inside the tech building.
4. The extent of the post-race inspection shall be at the discretion of the chief tech inspector, but any car specification is subject to post-race inspection.
5. If the car is in violation of any car specifications, as determined by the tech inspectors, the car owner and/or driver is subject to one or more penalties at the discretion of the Competition Committee.
6. Before a final determination is made, the car owner shall be informed of the specific violation and shall have the option to remove or disassemble that part of the car or engine necessary to provide a more thorough examination.
7. If the car owner refuses this optional tear down, the car shall be deemed illegal and the car owner and/or driver is subject to one or more penalties at the discretion of the Competition Committee.
8. If a car is in violation of any car specification, the Chief Technical Inspector reserves the right to confiscate and keep the illegal component or part.
9. If the car owner refuses the initial post-race inspection, the car shall automatically be deemed illegal and the car owner and/or driver shall be subject to one or more penalties at the discretion of the Competition Committee.
10. For questions on car specification please call Oswego Speedway at 315-342-0646.

CHAPTER TEN

1. PUSH VEHICLES – All push vehicles shall be equipped with a front push “bumper/surface” capable of safely allowing a race car to be moved, or push started without causing damage to the rear of the car being pushed. The rear bumper contact surfaces, for both the supermodifieds, and the limited supermodifieds have been standardized in the **2012-2013 Rule Book**. The speedway is requesting all push truck owners ensure their push bumpers are compatible with current race car bumper rules. The recommended Push Truck Push Bumper dimensions are as follows:

- 8” Ground to bottom of push surface, recommended. This is to ensure the push bumper surfaces don’t ride up and over the supermodified rear bumpers.
- 24” Ground to the top of the push surface, recommended. This is to ensure contact with the rear bumpers of all divisions.
- 24” – 30” Push surface width recommended. This to ensure a narrow enough push surface, to avoid contact with the tail side panels, when pushing around corners.
- 15” – 18” Push surface extended out in front of the push truck headlight/ bumper area recommended. This is to minimize the likelihood of contact between the super rear tail side panels, and the push truck headlight/ bumper areas.

CHAPTER ELEVEN

SPEEDWAY POLICY REGARDING USE OR POSSESSION OF ILLEGAL DRUGS OR SUBSTANCES - All Divisions

1. **ILLEGAL DRUG DEFINITION:** Illegal drugs are those substances defined and prohibited by state and/or federal law.
2. **GENERAL PROHIBITION:** Possession or use of illegal drugs or drug substances, as defined above, is prohibited in any form, by any participant at Oswego Speedway, either on the speedway grounds, or in any area considered to be used in the operation of Oswego Speedway, such as parking lots or any other properties.
3. **PARTICIPANT, DEFINITION:** A participant is any person taking part in any event at Oswego Speedway, in any form, including, but not restricted to drivers, car owners, mechanics, crew members, sponsors, track officials and pit area observers. All such persons shall be considered public figures who have by their own choice become involved in auto racing events at Oswego Speedway, with full understanding that they shall abide by the rules and regulations established and published and/or announced by Oswego Speedway. All participants are considered to be responsible for their personal conduct.
4. **VIOLATIONS & PENALTIES:** Any person found to be in possession of or under the influence of an illegal drug or drug substance on speedway property, as defined above, or any person who is arrested by duly-constituted authorities and charged with possession and/or use of illegal drugs or drug substance, or any person who is formally charged by a court of law with illegal drug violations, shall be subject to eviction from speedway property and denial of further entry to the speedway for a period to be determined by the Competition Committee.
 - a) Any participant who is formally charged by a court of law with an illegal drug violation, upon notification to the Competition Director by that agency, shall be suspended from all forms of participation at Oswego Speedway until such time as charges are fully adjudicated through the legal process. Any participant convicted of a formal drug charge by such process of law shall be prohibited from taking part in any Oswego Speedway events for a period to be decided by the Competition Committee, from date of conviction.
5. **APPEAL AND HEARING:** Any participant suspended for violation of these rules shall be granted a hearing by a board of appeals to be designated by the Competition Committee, provided the suspended participant requests such a hearing, in writing, within 14 calendar days of the date of suspension. It is the responsibility of the suspended person to make such a request if a hearing is desired.
6. **REINSTATEMENT:** A participant suspended for drug violations as outlined above, except in the case of a person charged with selling drugs, may, as the result of a decision reached through the hearing process detailed above, be reinstated, if the participant, at his or her own expense, produces documentation from a physician, licensed within the State, certifying that he or she is drug independent, as a result of random and periodical examinations and urinalysis testing, made at the request of the Competition Director.

7. PRESCRIPTION DRUGS: If a participant is using prescription drugs on advice from a physician it shall be reported to the Competition Director prior to entering speedway activities. If not reported, the participant shall be subject to one or more penalties at the discretion of the Competition Committee.

CHAPTER TWELVE

CHAMPIONSHIP POINT SYSTEM - All Divisions

1. Single championship points shall be awarded for each feature.
2. A registered driver/car combination in attendance who makes a bona-fide attempt to compete in a qualifying or feature race, but fails to do so, shall receive 40 championship driver points. A driver who takes the white flag for a feature event shall not receive 40 points as he shall be awarded feature points for his designated finishing position.
3. In the event the last point race is rained out, the points accumulated through the last completed point show shall be used to determine the overall champion. No championship points shall be awarded for any races on Classic Weekend.
4. The Championship Point Fund shall be determined by 50/50 receipts and sponsorships secured by the end of the racing season and shall be paid at the Awards Banquet.
5. The owner and/or driver MUST be present at the Awards Banquet to be eligible to collect his/her portion of the Championship Point Fund.

TRACK CHAMPIONSHIP POINT SYSTEM FEATURE

Pos.....	Points
1st.....	100
2nd.....	94
3rd.....	90
4th.....	87
5th.....	84
6th.....	81
7th.....	78
8th.....	76
9th.....	74
10th.....	72
11th.....	70
12th.....	68
13th.....	66
14th.....	64
15th.....	62
16th.....	61
17th.....	60
18th.....	59
19th.....	58
20th.....	57
21st.....	56
22nd.....	55
23rd.....	54
24th.....	53
25th.....	52
26th.....	51
all other.....	50

HEAT POINTS

1st.....	15
2nd.....	12
3rd.....	10
4th.....	8
5th.....	7
6th.....	6
7th.....	5
8th.....	4
9th.....	3
10th.....	2
11th.....	1

CAR NUMBERS:

- (1) For scoring purposes, numbers must be as legible as possible. Numbers must be located on the front nose or hood, left and right quarter panels (upper portion) and rear.
- (2) Numbers must be a minimum of 18" high.
- (3) Numbers must not be partially obscured behind nerf bars, bumpers, body panels, tires or front nose wings.
- (4) The typeface used to create numbers must be bold and legible.

PAINTING GUIDELINES:

- (5) Numbers on dark or black paint should be in a contrasting light color to provide the highest possible legibility.
- (6) If dark color or metallic numbers are used, the number must be outlined with a lighter color or placed on a lighter background.
- (7) Numbers should be a solid color. Computerized blends and gradients are difficult for scorers to recognize. These numbers **MUST** be placed on a contrasting background or outlined in a contrasting color.



Examples of difficult-to-read numbers



Examples of easily-recognizable numbers

Notes: